

## SHORT COMMUNICATION

### Aspects of Threshold Switching

W. SMITH, R. F. SHAW† and H. K. HENISCH‡

*Materials Research Laboratory, The Pennsylvania State University, University Park, Pennsylvania  
16802, U.S.A.*

*(Received May 14, 1974)*

It is shown that the delay time of a chalcogenide glass threshold switch is not significantly affected by strong illumination, sufficient to increase the conductance by an order of magnitude. This means that the initiation of threshold switching is not due to free carriers within the bulk material. Noise measurements in the pre-threshold region demonstrate the existence of noise, in excess of thermal noise, increasing sharply towards the threshold point. The results suggest impact ionization by carriers originating at the electrodes as the best available hypothesis for the nature of the threshold condition.

In previous publications<sup>1,2</sup> we have reported on the behaviour of multicomponent chalcogenide threshold switches under illumination and, in particular, on the fact that the threshold voltage at room temperature was found to be independent of illumination. This was held to be an important model-testing criterion, inasmuch as the illumination produced order-of-magnitude changes of carrier concentration and power dissipation at the threshold point. It was concluded from the constancy of that voltage that the threshold instability criterion involves a critical field. The same conclusion follows from the measurements of Adler and co-workers<sup>3</sup> under electron bombardment, and of M. Shaw<sup>4</sup> and ultrashort pulse excitation. It is also in harmony with observations by Buckley and Holmberg<sup>5</sup> on the threshold switching properties of memory alloys of varying thickness. Impact ionization or tunnel penetration were believed to be the processes involved; previous experimentation did not permit a choice between them. Even now, a firm decision is impossible, but some of the results described below suggest that impact ionization is the best available hypothesis.

In the course of more recent experiments, measurements were made not only of the threshold voltage but also of the corresponding switching delay. Test specimens were made by sputtering a 0.5–1.0  $\mu\text{m}$  thick film of  $\text{Te}_{40}\text{As}_{35}\text{Ge}_7\text{Si}_{18}$  on to a substrate of

conducting  $\text{SnO}_2$ , which acted as a transparent electrode. A point contact of pyrolytic graphite was used as the counter electrode. In these units, threshold voltage and switching delay were subject to statistical variations from event to event. Moreover, for a given externally applied voltage, the actual voltages which appear across the specimen in darkness and under light are, of course, very different. In order to overcome this problem, two pulse generators were used as shown in Figure 1. The two amplitudes were adjusted so as to ensure that the Generator A supplied a high level, Generator B a low level pulse, the two outputs being additive for measurements under light and subtractive for measurements in darkness. In this way, the effect of photoconduction was compensated and the pulse voltage applied to the specimen kept constant. Systematic drifts were minimized by alternating measurements in light and in darkness. Two typical runs averages for 10 events yielded:

	Device 1 ( $V_{\text{ON}} = 20.5 \text{ V}$ )	Device 2 ( $V_{\text{TH}} = 17 \text{ V}$ )
In darkness:	$0.76 \pm 0.41 \mu\text{sec}$	$2.6 \pm 1.6 \mu\text{sec}$
Under light:	$0.62 \pm 0.24 \mu\text{sec}$	$2.4 \pm 1.3 \mu\text{sec}$

Though light produced a measurable change, it will be seen that, for any given voltage, the mean delay time is not significantly affected by illumination, even though that illumination was of an intensity high enough to modulate the threshold conductance by an order of magnitude. Under such conditions, previous work<sup>1,2</sup> reported *some* reductions of threshold

†Address: Exxon Research and Engineering Co., Linden, N.J. 07036.

‡Also affiliated with the Department of Physics.

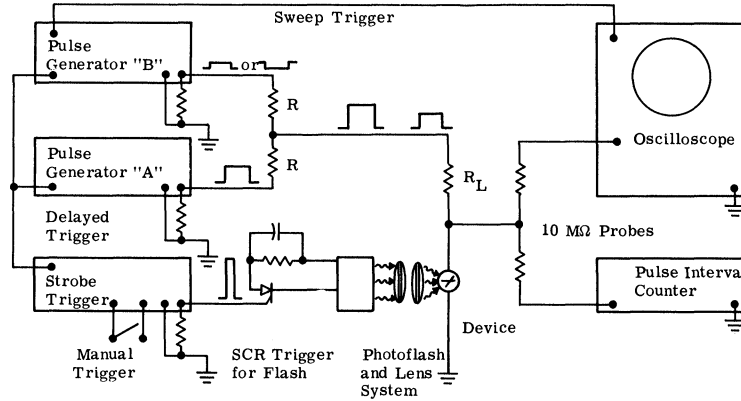

FIGURE 1 Experimental arrangement for switching delay measurements under pulsed light.

voltage, but the reductions were only of the order of 1% and of doubtful statistical significance. Corresponding to such a change, one would expect a reduction of delay time of the same magnitude as here observed. There is therefore no evidence whatever that light, even light of high intensity, leads to any change of switching delay time, other than that expected from the slight increase of overvoltage implied by the previously established results.

In the ordinary way, one would have expected the switching delay to *diminish* with illumination, even though the critical field criterion might remain the same. This expectation follows from the fact that a successful breakdown attempt should occur distinctly *earlier* when the number of participating carriers is greatly augmented. Electrical breakdown in gases is a good example of a process which obeys this general rule; the threshold switches here examined evidently are not. It becomes necessary to argue either (a) that the free carriers are not responsible for initiating the switching process, or (b) that they are responsible, but originate from the electrodes (as distinct from the bulk), where their concentration is unaffected by the incident radiation<sup>6</sup>. Hypothesis (a) would imply that the switching process is *initiated* by carriers in states which are always full (even in darkness), e.g. electrons in some of the trapping states within the mobility gap. However, a model which accounts convincingly for the statistical character of the delay time and for the temperature dependence of the threshold voltage on this basis has not yet been found. In view of this, further investigations into alternative (b) and the possibility of impact ionization were made, as described below. Meanwhile, it should be noted that *any* effect which leads to a *local* increase of conductivity should ultimately (through field re-distribution) lead to a barrier-controlled ON-state.

If the initiation of switching were to involve impact ionization, one would expect "unsuccessful" switching attempts to be made at fields just below the critical value, i.e. attempts which lead to partial breakdown which cannot be sustained. The result would be an excess of shot noise. This is indeed observed, as Figure 2 shows. The experimental

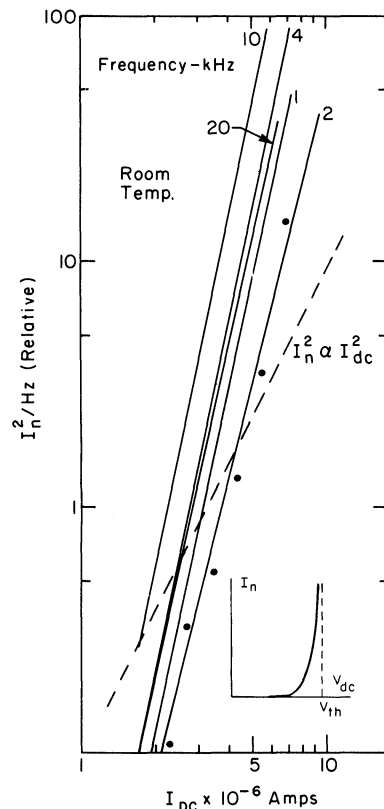

FIGURE 2 Typical noise output of a chalcogenide alloy threshold switch with graphite electrodes.

arrangement for the current noise measurements consisted of an operational amplifier integrator which supplied a well filtered positive or negative ramp voltage of variable slope to the switch, and also to the X-terminals of an X-Y recorder, at a rate of 50 mV/sec.

The specimens† used for the noise measurements were encapsulated units of the above composition, with two graphite electrodes. Devices were first switched several times and then allowed to “rest” for one-half hour. The ac component across a 100  $\Omega$  resistor in series with the device was filtered by a unity gain filter adjusted for a constant 200 Hz bandpass at the center frequency.

Figure 2 shows that  $(I_n^2/\text{Hertz})$  is proportional to  $I_{dc}^\beta$ , where  $\beta = 4.8 \pm 1.5$ , averaged over all devices and temperatures. The traditional interpretation of current noise has developed from fixed gain systems such as photomultipliers or from semiconductors of ohmic behaviour with a distribution of traps<sup>7,8</sup>. This analysis leads to a  $1/f$  frequency dependence and an  $I_{dc}^2$  current dependence. The current noise behaviour in the present devices shows an excellent  $1/f$  frequency relationship, but the departure from the  $I_{dc}^2$  current dependence is significant.  $\beta > 2$  implies a system of variable (i.e. current dependent) gain, e.g. via internal field enhancement under a fixed applied voltage. Impact ionization is such a process. In the devices examined ( $V_{TH} \approx 12$  V), the noise began to be significant at 8 V and increased very sharply towards threshold (see insert), as one would expect. The noise results are thus qualitatively compatible with impact ionization, even though they cannot incontrovertibly identify such a process.

Impact ionization is linked with the notion of a critical field. There is, however, one situation in which the critical field criterion *appears* to break down, i.e. during the recovery period after a switching event. During that time the breakdown voltage recovers from a value equal to the holding voltage to the original threshold value. From the decay process transient of the ON-characteristic, Lee and Henisch<sup>9</sup> have derived a characteristic time ( $\sim 10^{-7}$  sec) which was tentatively regarded as the lifetime of free carriers. The contention was that a dense electron-hole plasma exists immediately following the cessation of an ON-state, a plasma which then decays, mostly thermally but to some extent also by radiative

emission<sup>10</sup>. However, Pryor<sup>11</sup> subsequently found that the times so evaluated were somewhat dependent on circuit capacitance. This leads to the suggestion<sup>6</sup> that such measurements relate not to bulk decay but to carrier loss into the electrodes. In order to explain the initial low value and later recovery of the threshold voltage, it would be necessary to assume that the carrier concentration loss is faster in the regions near the electrodes than in the interior of the switch. Tunneling through electrode barriers was believed to be responsible for the nature of the transient ON-state<sup>12</sup>, and the gradual decay of excess carriers would have the result of thickening those regions. If the re-initiation of breakdown demands a critical field, the applied voltage required for switching must increase likewise. The critical field criterion is thus not in conflict with the observed recovery behavior.

The present delay-time observations were essentially similar on specimens of different thickness. In conjunction with hypothesis (b), this suggests that carriers which initiate breakdown are hot when they leave the electrode, and thus have an energy advantage over carriers generated optically.

The present model will no doubt undergo changes and refinements as further experimental results become available. It is, meanwhile, an attempt to provide a self-consistent basis for the available threshold switching observations made in darkness and under light.

#### REFERENCES

1. W. R. Smith and H. K. Henisch, *Phys. Status Solidia* **17**, K81 (1973).
2. H. K. Henisch, W. R. Smith and M. Wihl, *Proc. 5th Int. Conf. on Amorphous and Liquid Semiconductors, Garmisch, Germany* (September 1973), in print.
3. D. Adler, *J. Vac. Sci. Technol.* **10**, 728 (1973).
4. M. Shaw, S. H. Holmberg and S. A. Kostylev, *Phys. Rev. Lett.* **31**, 542 (1973).
5. W. D. Buckley and S. H. Holmberg, *Personal communication*.
6. Sir Nevill Mott, *Personal communication*.
7. A. Rose, *Vision*. (Plenum Press, New York, 1973).
8. R. King, *Electrical Noise*. (Chapman and Hall, London, 1966).
9. S. H. Lee and H. K. Henisch, *Solid State Electron.* **16**, 155 (1973).
10. B. T. Kolomiets, E. A. Lebedev, N. A. Rogachev and V. Kh. Shpunt, *Sov. Phys. - Semicond.* **6**, 167 (1972).
11. R. W. Pryor, *Solid State Electron.* **16**, 425 (1973).
12. R. W. Pryor and H. K. Henisch, *J. Non-Cryst. Solids* **7**, 181 (1972).

†Supplied by Energy Conversion Devices, Inc. through the courtesy of S. R. Ovshinsky.



**Hindawi**

Submit your manuscripts at  
<http://www.hindawi.com>

