

UNDERWATER ACOUSTIC MEASUREMENTS ON POLYVINYLIDENE FLUORIDE TRANSDUCERS

B. WOODWARD and R. C. CHANDRA

*Electronic and Electrical Engineering Department, Loughborough University of Technology,
Loughborough, Leicestershire, U.K.*

(Received December 21, 1977)

Methods of making piezoelectric transducers from very thin sheets of polyvinylidene fluoride (PVDF) are discussed, together with techniques for calibrating these devices, particularly for underwater operation. Parameters measured include receiving response, source level, beamwidth, characteristic impedance and variation of impedance with frequency. Consideration is also given to the dependence of receiving response on the poling fields and temperatures used in making PVDF transducers. Because of their broadband response thin sheet PVDF transducers have been shown to be ideal for monitoring the true form of acoustic pulses underwater.

1. INTRODUCTION

Polyvinylidene fluoride (PVDF) has been studied intensively since 1969 when its piezo-electric properties were discovered in Japan.¹⁻³ The material has been used for a long time as a packing and insulating material, but now that it is obtainable in sheets as thin as 6 μm there is a current interest in its possible application as a broadband piezo-electric transducer.

In this paper, emphasis is given to underwater measurements, and the dependence of the acoustic sensitivity of PVDF transducers on the poling fields and temperatures used during their construction. This area of study has arisen because PVDF has a characteristic acoustic impedance close to that of water, making it suitable for underwater use. Its acoustic impedance, measured here as 3.94×10^6 rayl, is quite close to the impedance of water (approximately 1.5×10^6 rayl), thereby ensuring good acoustic matching.

Of all the polymers which behave piezo-electrically, PVDF has the highest piezo-electric constants.² Although its relative dielectric constant is very low, varying between 9 and 15 depending on frequency and mechanical compliance, its piezo-electric g_{33} constant is very high.⁴ Together with the good matching to water, this indicates that PVDF should be a potentially sensitive underwater transducer for broad band use.

PVDF is comparatively cheap, lightweight, transparent, flexible, resistant to mechanical and thermal shock and to chemical attack, and is available

in large area sheets, suitable for making cheap transducer arrays. Electrodes can be vapour-deposited onto its surface and it can be poled with much lower D.C. voltages than are used for poling conventional ceramic transducers. The piezoelectricity of PVDF is stable with time at temperatures below 80°C, and its high capacitance, measured here as 500 pF cm^{-2} , makes it suitable for use at low frequencies when the signal is fed to a low input impedance instrument.

2. TRANSDUCER CONSTRUCTION

The PVDF samples used in this study were in the form of very thin sheets manufactured by the Kureha Chemical Industry Company, Japan. The sheets were 25 μm thick and biaxially oriented (BO), i.e. during manufacture they were stretched both parallel and perpendicular to the direction of extrusion.

In principle, any dielectric contains electric charges that at a given temperature can be oriented by an electric field. If the dielectric is then cooled so that the charges are immobilised, it will act as the electrical equivalent of a permanent magnet and is called an electret, or more correctly, a thermoelectret. If this treatment is applied to PVDF a piezoelectric device is obtained.

It is usually convenient to provide the PVDF with electrodes before poling. This may be done by vapour deposition of a metal in a vacuum chamber, and for permanent adhesion the metal must be bonded chemically to the polymer surface. This necessitates

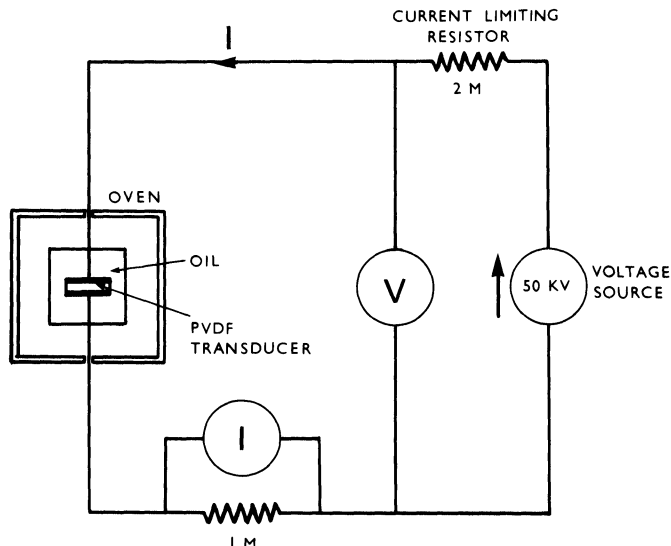

FIGURE 1 Poling arrangement.

the use of reactive metals such as aluminium, nickel, chromium and nichrome. Electrodes with simple geometry are readily made by evaporating onto the PVDF through a suitable metal mask. For an array of very small electrodes it is better to use photolithographic techniques.⁵

In this laboratory the electrode metal used was aluminium, which was evaporated after the surfaces of each PVDF sample were H.T. cleaned, i.e., the surfaces were bombarded with nitrogen atoms. After electroding, permanent poling was achieved by applying a high D.C. electric field, each sample being immersed in an electrically non-conducting oil heated to a specific temperature (Figure 1). Typically, the oil was heated to between 60°C and 105°C. The D.C. voltage was applied only when the pre-determined temperature had been attained. This voltage, ranging from 1000 V to 3000 V, was applied for 15 minutes, then the sample was removed from the oil to cool to room temperature with the voltage still applied. For 25 μm PVDF sheets, these voltages were equivalent to electric fields of 40 $\text{V } \mu\text{m}^{-1}$ to 120 $\text{V } \mu\text{m}^{-1}$. Poling currents varied considerably for each transducer, and varied during poling, but were typically 500 nA or less.

The poling temperature cannot be increased much above 100°C before the combination of temperature and field results in dielectric breakdown of the material. The highest temperature used in our work was 110°C. The poling field can, however, be increased but a transducer having good piezoelectric response can be obtained if the field is at least 100 V

μm^{-1} .⁶ The total time that the field was applied was between 15 and 30 minutes, but this could have been much longer.⁷

An attempt was made to specify the type of material being used, since PVDF exists in three forms, referred to as phase I (β -form), phase II (α -form) and phase III (γ -form), which can exist separately or together. Phase I, with dipoles in the polymer chains packed in a parallel array, can be described as non-centrosymmetric and polar, and largely determines the piezoelectric behaviour of PVDF. Phase II, with the dipoles packed in an anti-parallel array, is centrosymmetric and polar, and phase III is a sheared modification of phase I.⁶

The method of identifying these forms was from infra-red absorption spectra, obtained for wave numbers between 250 cm^{-1} and 1000 cm^{-1} . Comparison with spectra previously published⁸ indicated that the material was predominantly phase II (α -form). However, by a criterion⁹ that the amount of each phase can be estimated from the absorbance ratio D_{510}/D_{530} , it appears that the material consisted of approximately equal amounts of phase I and phase II (Figure 2).

There is evidence that the morphology of PVDF changes during poling.⁸ This was briefly investigated by studying the infra-red spectra before and after poling two 25 μm samples whose poling parameters were 80 $\text{V } \mu\text{m}^{-1}$ at 80°C and 60 $\text{V } \mu\text{m}^{-1}$ at 95°C.

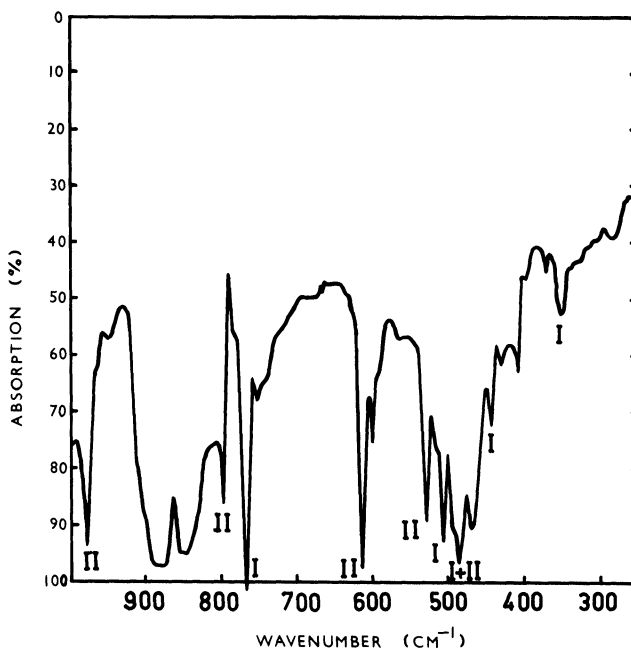

FIGURE 2 Infra-red spectrum.

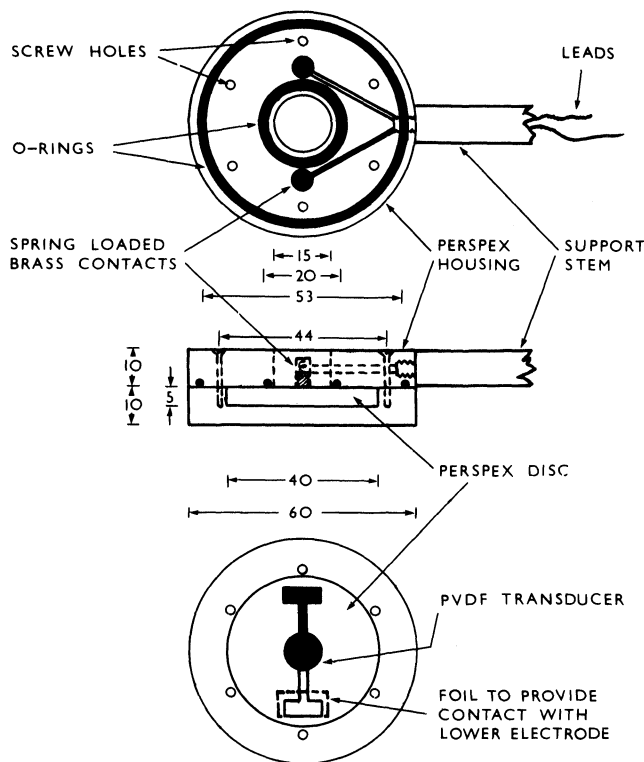

FIGURE 3 Transducer housing (dimensions in mm).

No significant differences in any of the spectra could be detected.

The transducers made by the techniques described above were mounted in a nylon housing (Figure 3) for all underwater measurements. Each transducer was rigidly backed by carefully sticking it onto a perspex disc with quick-setting adhesive until it was perfectly flat, thus ensuring that it vibrated in only the thickness extension (TE) mode.

3. INSTRUMENTATION

Figure 4 shows the instrumentation used for most measurements of receiving response, source level and beamwidth. A 300 kHz continuous wave signal from an oscillator (Marconi type TF885A/1) was interrupted by a gating system (Brüel and Kjaer type 4440), which supplied a train of output pulses to the projector (PZT-4 for receiving response and beamwidth measurements, PVDF for source level measurements). The transmit pulse length was usually 200 μ s but this could be varied over a wide range.

Acoustic signals detected by the hydrophone (PVDF usually, a commercial type LC-10 for source level measurements) were amplified 40, 60 or 80 dB by a microphone amplifier (Brookdeal type 453). The amplified signals were then fed to the receive side of the gating system, which gave two separate outputs for measurements. An a.c. output was used for monitoring the received train of pulses on an oscilloscope, triggered by the transmit gate. Alternatively part of the received train (say the first echo) could be gated, giving a d.c. output from a peak detector which could be monitored by an AVO meter. The second method was preferable since it gave a more accurate measurement.

Since the gating system had a high-frequency cut-off at 338 kHz, an alternative arrangement was used for measurements at higher frequencies. For measurements up to 3 MHz the oscillator and gating system were replaced by a Harwell (95 series) system, but the principle of operation was the same.

For beamwidth measurements, the stem of the PVDF transducer holder was supported by a turntable carrying a needle which moved across a sheet of polar graph paper. Variations of received signal amplitude with rotation of the PVDF transducer about its vertical axis were obtained from the gating system's d.c. output and were accurate to 0.5°.

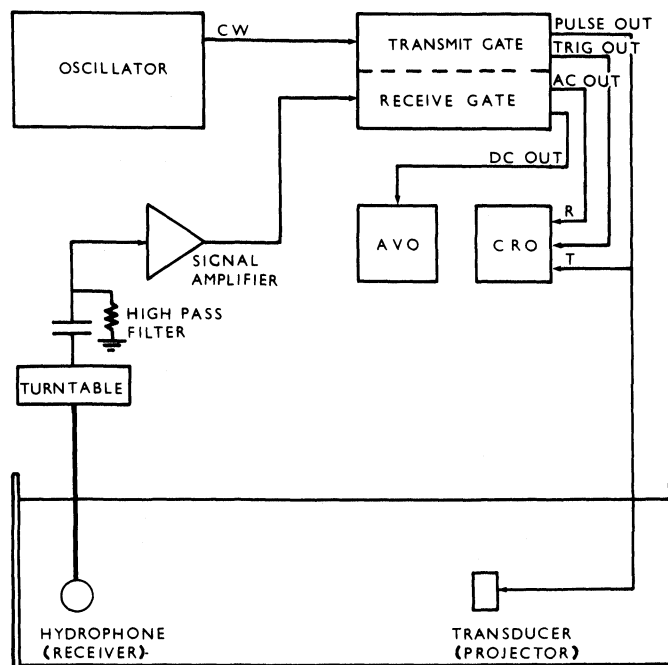

FIGURE 4 Instrumentation.

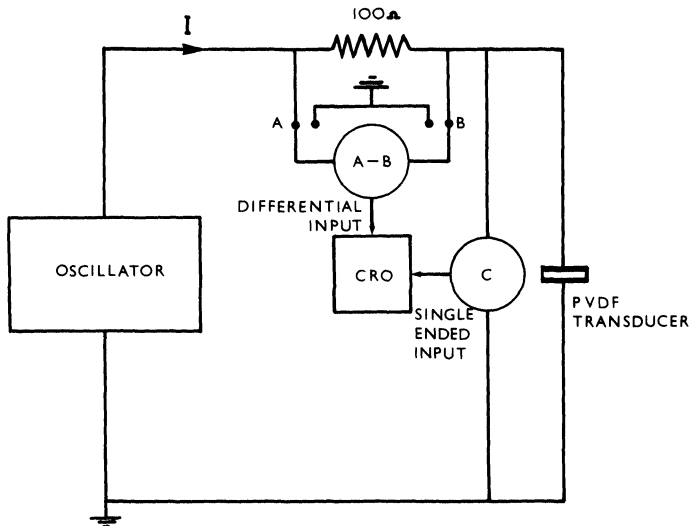

FIGURE 5 Circuit for impedance and admittance measurements.

To obviate the problem of mains pick-up by the hydrophone, a simple high pass RC filter was designed. The cut-off frequency was determined by:

$$\begin{aligned} f &= 1/2 \pi RC \\ &= 1/2 \pi (1000)(0.047 \times 10^{-6}) \\ f &= 3.386 \text{ kHz} \end{aligned}$$

This is well above the troublesome 50 Hz pick-up and was found to work perfectly.

For velocity of sound measurements, a separate ultrasonic interferometer was used. The measuring technique is described in Section 4.5.

For impedance and admittance measurements a PVDF transducer was driven by the Marconi oscillator, and measurements of voltage and current were obtained with the arrangement shown in Figure 5. The oscilloscope (Telequipment type D63) had a single-ended input for voltage measurement, and a double-ended differential input for current measurement. The impedance $|Z|$ is given by:

$$|Z| = \frac{C - (A - B)}{(A - B)/100} = \left[\frac{C}{A - B} - 1 \right] \times 100$$

The admittance $|Y|$ is given by $|Y| = |Z|^{-1}$

4. MEASUREMENTS

4.1. Dependence of Receiving Response on Poling Parameters

There is no fixed set of poling parameters for

producing a PVDF piezoelectric transducer. A large combination of poling temperatures and poling fields, applied for a wide range of times, will result in a working device. Various piezoelectric constants have been shown to depend on the poling parameters,¹⁰ but there are no known results showing how the open-circuit receiving response of an underwater PVDF transducer depends on them.

This dependence was studied by measuring the relative receiving responses of a number of transducers at 3 MHz. A plot of receiving response (in mV_{pp}) against temperature for electric fields of 40, 60, 80 and $108 \text{ V } \mu\text{m}^{-1}$ is shown in Figure 6. The projector-receiver separation of 100 mm ensured that measurements were obtained in the far zone, which is defined as extending from axial distances of $d^2/4\lambda$, where d is the transducer diameter and λ is the wavelength of sound in water. At 3 MHz, λ is 0.5 mm and $d^2/4\lambda$ for a 10 mm diameter PZT-4 projector is 50 mm.

The best fit lines for fields of 40, 60 and $80 \text{ V } \mu\text{m}^{-1}$ were obtained by regression analysis, and the equations of these lines are shown on Figure 6. Thus, for a given poling field there is an approximately linear dependence of response on temperature. However, there appears to be little difference in response between those transducers poled at $80 \text{ V } \mu\text{m}^{-1}$ and those poled at $108 \text{ V } \mu\text{m}^{-1}$, for which no best-fit line is drawn.

The maximum response (for poling parameters of $108 \text{ V } \mu\text{m}^{-1}$ at 105°C) is greater than the minimum response ($40 \text{ V } \mu\text{m}^{-1}$ at 65°C) by 11 dB.

Figure 6 exhibits similar characteristics to some of our previous results for freely-mounted 20 mm diameter PVDF transducers, which were obtained for the same temperature range but with much lower fields.⁴ The majority of results for freely-mounted transducers were obtained for poling fields below $40 \text{ V } \mu\text{m}^{-1}$, but a few that were obtained for fields up to $165 \text{ V } \mu\text{m}^{-1}$ showed no levelling off of response with increase of field.

Since the PVDF was very thin and therefore receiving well below its thickness resonant frequency,⁷ each point on Figure 6, representing the response of a particular transducer, could be expected to move only marginally for a broad band of frequencies.

4.2. Absolute Receiving Response

The receiving response (M_H) of an underwater transducer is the open circuit voltage (V) generated by a plane wave of unit r.m.s. pressure (p), i.e.

$$M_H = V/p$$

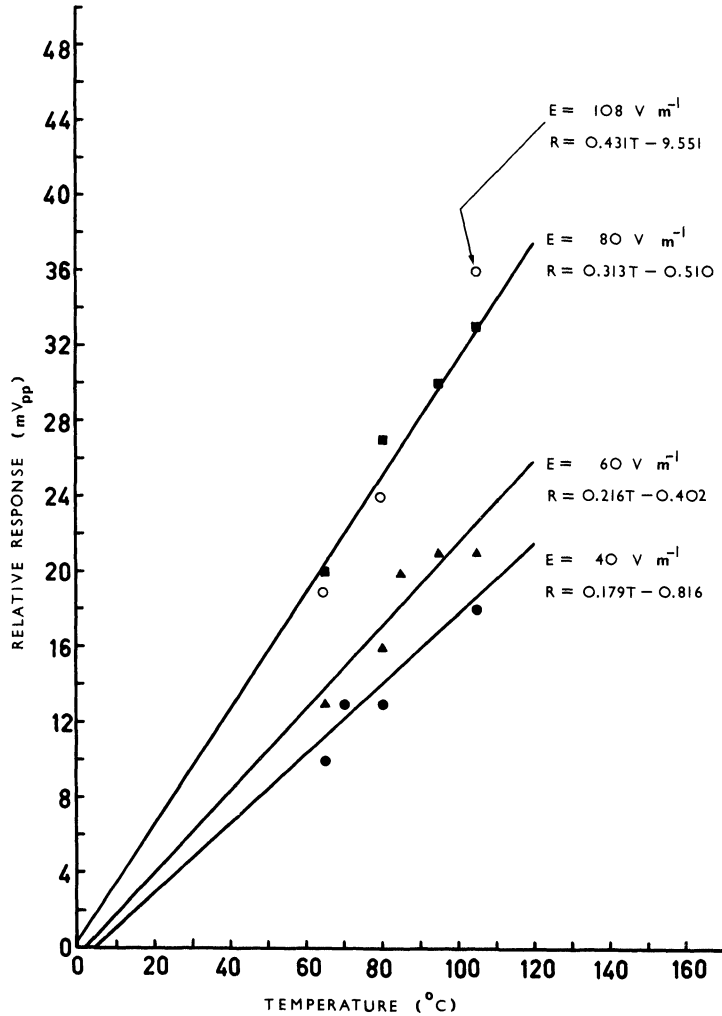

FIGURE 6 Relative receiving response as a function of temperature for different poling fields.

M_H is expressed in $\mu\text{V } \mu\text{bar}^{-1}$ or V Pa^{-1} and $20 \log M_H$ is expressed in dB relative to $1 \text{ V } \mu\text{bar}^{-1}$ or dB relative to 1 V Pa^{-1} .

The absolute receiving responses of PVDF transducers were obtained by direct comparison with the response of a calibrated LC-10 hydrophone. At 300 kHz the LC-10 had a calibration of:

$$M_H = 5.5 \mu\text{V Pa}^{-1}$$

$$20 \log M_H = -105 \text{ dB (re } 1 \text{ V Pa}^{-1}\text{)}$$

A number of 10 mm diameter PVDF transducers were calibrated, the most sensitive having a response approximately given by:

$$M_H = 0.5 \mu\text{V Pa}^{-1}$$

$$20 \log M_H = -126 \text{ dB (re } 1 \text{ V Pa}^{-1}\text{)}$$

This is about one-tenth the sensitivity of the LC-10 hydrophone, but because of its broadband characteristic the PVDF transducer should have the same response over a very wide range of frequency up to its fundamental thickness resonance of approximately 20 MHz.

4.3. Source Level

The source level of a transducer is arbitrarily defined as:

$$S.L. = 10 \log p_1^2 = 20 \log p_1$$

where p is the r.m.s. acoustic pressure 1 m from the transducer. The units are dB relative to $1 \mu\text{Pa}$. For large sonar arrays the pressure field is complex for

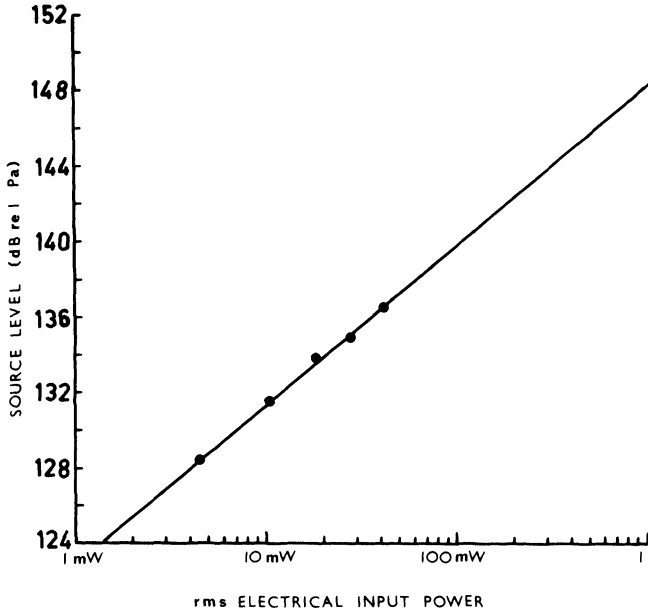

FIGURE 7 Source level plot.

many metres out along the transmission axis. Thus, the pressure is often measured in the far zone and a value of source level is obtained by adding on the transmission loss due to geometrical spreading. For spherical law spreading, the transmission loss is $20 \log r$, where r is the range.

For the 10 mm diameter PVDF transducers the far zone started at approximately $r = 5$ mm at 300 kHz, therefore source level could be measured directly at 1 m and no transmission loss extrapolation was necessary.

Figure 7 shows a linear-logarithmic plot of source level in dB relative to $1 \mu\text{Pa}$ against r.m.s. electrical input power for a PVDF transducer having an effective resistance of 2.8 kohm at 300 kHz (from Figure 12). The source level for 100 V_{pp} drive voltage is 145.2 dB relative to $1 \mu\text{Pa}$.

This source level is so low that it is unlikely that PVDF would be suitable as a sonar projector other than for very short range applications, such as medical diagnosis.

4.4. Beamwidth

The beamwidth of any circular disc transducer depends on the directivity function D defined by:

$$D = \frac{2J_1(k.a. \sin \theta)}{k.a. \sin \theta}$$

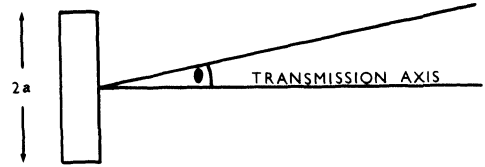

FIGURE 8 Transducer beam angle.

where a = transducer radius
 $k = 2\pi/\lambda$
 J_1 = first order Bessel function
 and θ is given by Figure 8

Tables of Bessel functions show that $D = 0$ when $k.a.\sin \theta = 3.83, 7.02, 10.17, 13.32 \dots$, indicating that the acoustic energy generated by the transducer is distributed in lobes. A plot of D against $k.a.\sin \theta$ enables all calculations of beamwidth angles to be made for a given radius. Since this graph gives values of $k.a.\sin \theta$ for any value of D up to 1, the half-power and quarter-power beamwidths can be predicted. These are the angles at which the intensity falls to 0.5 (3 dB down) and 0.25 (6 dB down) respectively, of the intensity on the transducer axis. This corresponds to values of D of 0.707 and 0.5 respectively.

The half-power beamwidth is given by $k.a.\sin \theta = 1.6$. This means that at 300 kHz the -3dB beamwidth is given by $\theta_{-3dB} = 2\sin^{-1}(2.546/d)$ where d is the diameter of the transducer in mm. Similarly, the -6dB beamwidth is given by $\theta_{-6dB} = 2\sin^{-1}(3.344/d)$ and the beamwidth of the main lobe, defined by the angles for which $D=0$ is given by $\theta_{D=0} = 2\sin^{-1}(6.1/d)$.

Thus for a 10 mm diameter transducer the predicted beamwidths are: $\theta_{-3dB} = 29.5^\circ, \theta_{-6dB} = 39.0^\circ$ and $\theta_{D=0} = 75.2^\circ$.

Measured beamwidths were obtained by rotating a PVDF transducer (used as a hydrophone) about its vertical axis in the field of a fixed 300 kHz PZT-4 resonant projector. Values obtained by this method for a 10 mm diameter transducer were $\theta_{-3dB} = 20^\circ, \theta_{-6dB} = 30.5^\circ$ and $\theta_{D=0} = 68^\circ$ (Figure 9). We consider that these values are lower than the predicted values because of the collimating effect of the transducer holder.

At higher frequencies the theoretical beamwidth decreases, and for a diameter of 10 mm, the 3 dB beamwidths at 1 MHz and 10 MHz are 8.75° and 0.875° respectively. However, measurements in this range, applicable to medical ultrasonics, were not made.

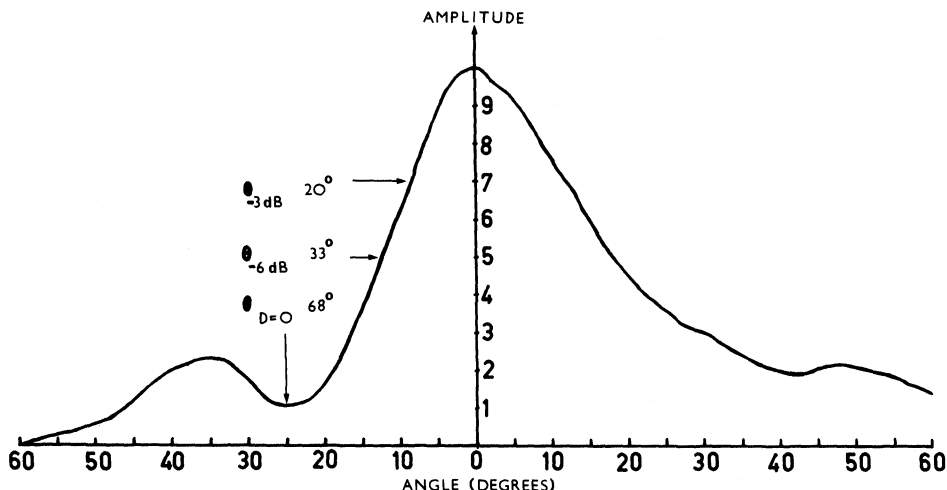

FIGURE 9 Linear beamplot for 10 mm diameter PVDF transducer.

4.5. Characteristic Impedance

The characteristic impedance of a material is simply the product of its density and the velocity of sound through it.

A simple ultrasonic interferometer was used for velocity of sound measurements, but the instrument did not have the resolution for measurements with the thin sheets previously used. Instead, a 3 mm thick sample of Solvay PVDF, made by Solvay & Cie (Belgium), was used. This material had a measured density of $1.799 \times 10^3 \text{ kg m}^{-3}$, approximately the same as for the 25 μm sheet.

The measurement arrangement is shown in Figure 10. A pulse was transmitted from the projector *P* to the reflector *R* with the PVDF sample, of thickness *t*, in contact with *P*. The round-trip transmission

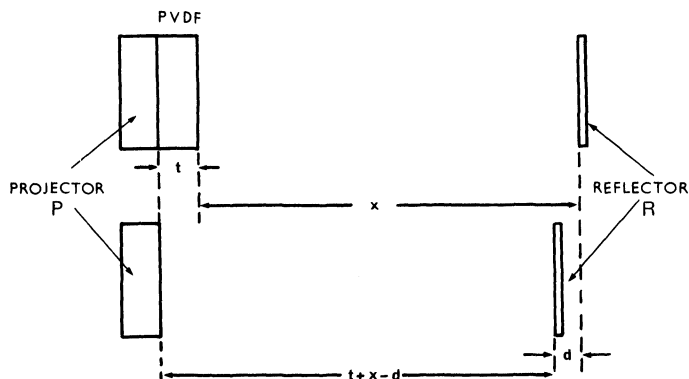

FIGURE 10 Arrangement for velocity of sound measurements.

time was displayed as an echo on an oscilloscope. Next, the sample was removed and the reflector moved towards the projector by an amount *d* until the displayed transmission time was the same as before.

The two situations may be expressed mathematically as:

$$\frac{2t + 2x}{v_p v_w} = \frac{2(t + x - d)}{v_w}$$

where v_p is the velocity of sound in PVDF and v_w is the velocity of sound in water.

Rearrangement gives:

$$\begin{aligned} \frac{t}{v_p} &= \frac{t - d}{v_w} \\ v_p &= \frac{t}{t - d} v_w \\ &= \frac{3}{2} \cdot 1460 \\ v_p &= 2190 \text{ ms}^{-1} \end{aligned}$$

By this method the velocity of sound was determined independently of the separation (*t* + *x*) of *P* and *R*, which in this experiment was about 100 mm. The value of v_w was measured at 20°C.

The product of density and velocity of sound gives the characteristic acoustic impedance (ρc) for PVDF as 3.94×10^6 rayl. This is about 8% greater than the value of 3.64×10^6 rayl recently published for 25 μm sheet.⁷

4.6. Frequency Characteristics

One of the most significant finds in this study was the behaviour of PVDF transducers as low-frequency receivers. Because of their non-resonant response over a broad range of frequency, they were found to be excellent devices for monitoring the nature and length of acoustic waves in water. Normally, the nature of a pulse as it is transmitted can only be roughly inferred by observing the waveform of the electrical pulse applied to a transducer. If this transducer has a high Q an applied pulse causes it to ring up to a steady state vibration amplitude, then ring down again so that the acoustic pulse is longer than the applied voltage pulse.

A PVDF hydrophone such as the one shown in Figure 3 can be used to visualise acoustic pulses transmitted by high Q projectors over the entire frequency range up to near its fundamental resonance of approximately 20 MHz. This is illustrated by the oscilloscope photograph shown in Figure 11. The upper trace shows a $100 \mu\text{s}$ pulse applied to a foam-backed PZT-4 projector at its series resonant frequency (f_0) of 297.92 kHz. The lower trace shows the much longer, and completely distorted, pulse received by the PVDF hydrophone after a propagation delay of $250 \mu\text{s}$. This is a true representation of the transmitted acoustic pulse.

The shape of the received pulse can in fact be calculated, for it is well known that a transducer

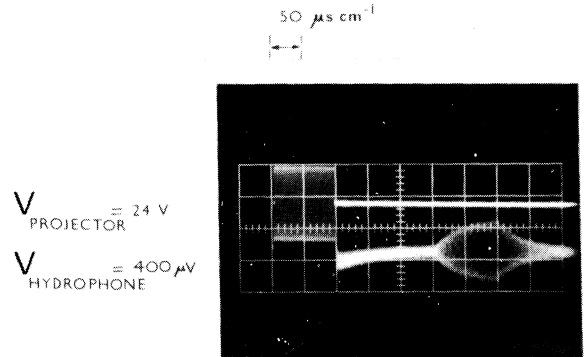

FIGURE 11 Oscilloscope traces of electrical pulse applied to a PZT-4 projector (upper trace) and corresponding transmitted acoustic pulse as detected by a PVDF hydrophone (projector voltage = 24 V, hydrophone voltage = $400 \mu\text{V}$, time axis grid $50 \mu\text{s}$ per division).

driven by a constant amplitude oscillating voltage takes Q/π cycles to reach 0.4 and Q cycles to reach 0.9 of its steady state energy dissipation. Similarly, it takes Q cycles to ring down to 0.1 of its steady state amplitude. Thus, an approximation of the transducer's Q can be obtained directly from a time-expanded oscilloscope trace of the pulse received by a PVDF hydrophone. This method gave a Q of 33.

An exact value of Q can be obtained from the series resonant frequency (f_0) and the half-power

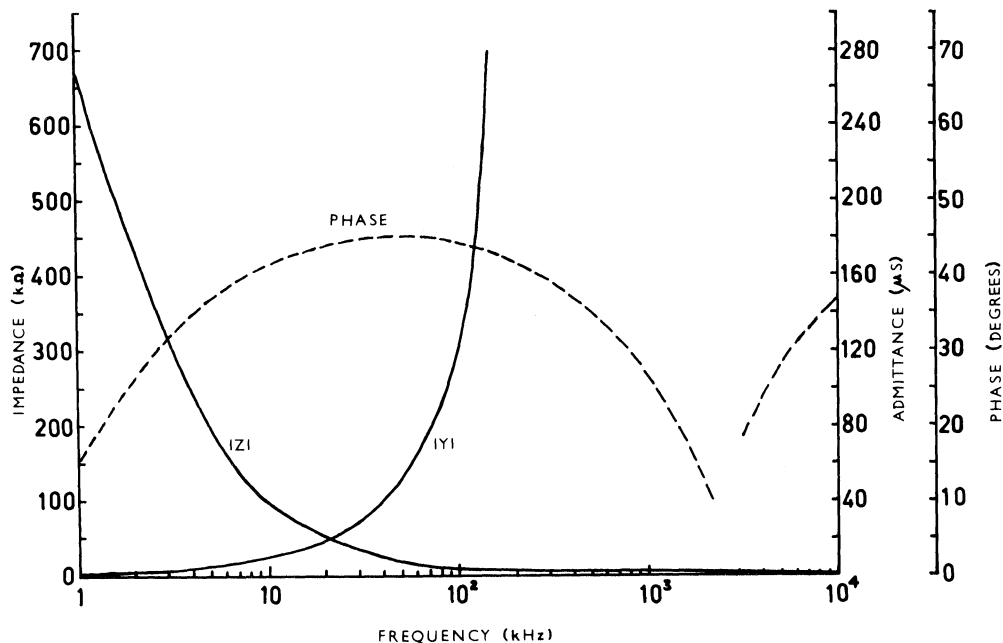

FIGURE 12 Variation of impedance and admittance with frequency.

frequencies ($f_{-1/2}$ and $f_{+1/2}$). These were found by monitoring the output of the PVDF hydrophone while altering the transducer frequency at constant voltage. f_0 is the frequency at maximum output; $f_{-1/2}$ and $f_{+1/2}$ are the frequencies either side of f_0 at which the output falls to 0.707 of the maximum value. For $f_0 = 297.92$ kHz, $f_{-1/2} = 293.20$ kHz and $f_{+1/2} = 302.20$ kHz. Q is given by:

$$Q = f_0 / (f_{+1/2} - f_{-1/2}) = 33.1$$

To calculate the time for the transducer to ring up, the period for one cycle at f_0 must be known, i.e.,

$$T = 1/f_0 = 1/(297.92 \times 10^3) = 3.36 \mu\text{s}$$

Since the transducer has a Q of 33.1 it takes $33.1 \times 3.36 = 111.2 \mu\text{s}$ to ring up to 0.9 of its steady state amplitude. This is $11.2 \mu\text{s}$ longer than the applied electrical pulse showing that the transducer was still ringing up at the end of the electrical pulse.

If the transducer takes the same time to quiesce to 0.1 of its steady state amplitude then the actual length of the generated acoustic pulse, is at least $100 + 111.2 = 211.2 \mu\text{s}$, or more than twice as long as the electrical pulse. This is borne out by Figure 11.

Since the PVDF sheets used here were only $25 \mu\text{m}$ thick, measurements of their electrical impedance (or admittance) were necessary to describe their broadband response. This was done with the arrangement shown in Figure 5. The variation of impedance and admittance with frequency over the range 1 kHz to 10 MHz is shown in Figure 12. The phase angle between voltage across the transducer and current flowing into the transducer is also shown.

Figure 12 can be used to calculate the effective resistance of PVDF at any frequency. This was done earlier in obtaining source level and can be illustrated for a specific measurement. At 300 kHz the phase angle was 42.3° and the impedance $|Z|$ was 3.9 kohm; thus the resistance was $R = |Z| \cos 42.3^\circ = 2.8$ kohm.

5. CONCLUSIONS

A range of underwater measurements on polyvinylidene fluoride (PVDF) has been made to describe its performance as an underwater transducer material. PVDF transducers made with a variety of poling parameters were found to have a receiving response dependent on the poling field, poling temperature and poling time. Their absolute response was 20 dB lower than that of the standard LC-10 hydrophone

used for calibrations, but this response could be considered constant up to about 20 MHz for $25 \mu\text{m}$ thick transducers.

PVDF transducers used as projectors were found to have very low source levels, and are likely to be of use only for very short range applications.

Beamwidth measurements agreed only approximately with theoretically calculated values, but we consider that this was because of the particular design of our transducer holder.

A value of 3.94×10^6 rayl was obtained for the characteristic impedance by measuring the velocity of sound and the density of Solvay PVDF.

PVDF hydrophones were found to be ideal for characterising acoustic pulses underwater because of their flat response over a wide frequency range. This led to a simple direct method of determining the Q of some source transducer by counting the number of cycles in the receiver waveform up to 0.9 of the peak amplitude.

The receiving response of PVDF is considered high enough for future development of a hydrophone by suitable poling techniques, and of a multi-element array for calibrating underwater acoustic fields.

REFERENCES

1. E. Fukada and S. Takashita, Piezoelectric effect in polarized poly(vinylidene fluoride), *Japan J. Appl. Phys.*, **8**, 960 (1969).
2. H. Kawai, The piezoelectricity of poly(vinylidene fluoride), *Japan J. Appl. Phys.*, **8**, 975-976 (1969).
3. T. Takamatsu and E. Fukada, Polyvinylidene fluoride electret, *Reports on Progress in Polymer Physics in Japan*, **12**, 417-420 (1969).
4. B. Woodward, The suitability of Polyvinylidene Fluoride as an underwater transducer material, *Acustica*, **38**, 264-268 (1977).
5. H. R. Gallantree and R. M. Quilliam, Polarized Poly(Vinylidene Fluoride) - Its application to pyroelectric and piezoelectric devices, *The Marconi Review*, **39**, 189-200 (1976).
6. G. R. Davies, PVDF - the all-purpose material?, *Institute of Physics Meeting on Piezoelectricity and Pyroelectricity*, London (25 May, 1977).
7. L. N. Bui, H. J. Shaw and L. T. Zitelli, Study of Acoustic Wave Resonance in Piezoelectric PVF₂ Film, *I.E.E.E. Transactions on Sonics and Ultrasonics*, **Su-24**, 331-336 (1977).
8. J. P. Luongo, Far-infrared spectra of piezoelectric polyvinylidene fluoride, *J. Polymer Sci.*, **10**, 1119-1123 (1972).
9. M. Latour, Infra-red analysis of poly(vinylidene fluoride) thermoelectrets, *Polymer*, **18**, 278-280 (1977).
10. N. Murayama, K. Nakamura, H. Obara and M. Segawa, The strong piezoelectricity in polyvinylidene fluoride (PVDF), *Ultrasonics*, **14**, 15-23 (1976).



Hindawi

Submit your manuscripts at
<http://www.hindawi.com>

