

Research Article

A New Capacitor-Less Buck DC-DC Converter for LED Applications

Munir Al-Absi, Zainulabideen Khalifa, and Alaa Hussein

Electrical Engineering Department, Faculty of Engineering, King Fahd University of Petroleum and Minerals, Dhahran, Saudi Arabia

Correspondence should be addressed to Munir Al-Absi; mkulaib@kfupm.edu.sa

Received 8 November 2016; Revised 23 December 2016; Accepted 28 December 2016; Published 17 January 2017

Academic Editor: Mingxiang Wang

Copyright © 2017 Munir Al-Absi et al. This is an open access article distributed under the Creative Commons Attribution License, which permits unrestricted use, distribution, and reproduction in any medium, provided the original work is properly cited.

In this paper, a new capacitor-less DC-DC converter is proposed to be used as a light emitting diode (LED) driver. The design is based on the utilization of the internal capacitance of the LED to replace the smoothing capacitor. LED lighting systems usually have many LEDs for better illumination that can reach multiple tens of LEDs. Such configuration can be utilized to enlarge the total internal capacitance and hence minimize the output ripple. Also, the switching frequency is selected such that a minimum ripple appears at the output. The functionality of the proposed design is confirmed experimentally and the efficiency of the driver is 85% at full load.

1. Introduction

Light emitting diodes (LEDs) are starting to experience widespread usage in many lighting applications. LEDs are replacing florescent lighting because of the LEDs' advantages compared to the florescent lamps. These advantages are mainly lower power consumption and longer life expectancy. However, commercial LED drivers limit the life expectancy of the LED lighting system to around one-fifth of the lifetime of the LED itself. The main reason of the driver short lifetime is the smoothing capacitor at the output. This is due to leakage in this capacitor, and hence this causes degradation in the driver performance with time. Several works on electrolytic capacitor-less LED drives have been presented to maximize the overall lifetime of the LED system and the recent states of the art are given in [1–7]. In [1], a current injection approach is used. In [2–7] several single-stage topologies using multiple switches or using shared switch techniques are presented. Most of the works presented require relatively complicated power circuits or current controlled technique to reduce the size of the energy storage capacitor. These topologies lead to larger area and higher cost. A new design of capacitor-less driver is presented in [8]. The design used a storage capacitor C_d and a two-winding dual inductor.

The major intention of this paper is to build upon the results obtained in [9] and present the mathematical model

and experimental results to confirm the functionality of the design. The rest of the paper is organized as follows: Section 2 describes the proposed design. Mathematical analysis and experimental results are given in Section 3. Section 4 concludes the paper.

2. The Proposed Design

The proposed design is based on the well-known buck converter shown in Figure 1, where the output voltage is the voltage across the load resistance R_L and C_0 . V_{p} pulse represents the controlling pulses generated from the control circuit. The DC output voltage is given by

$$V_{O(DC)} = \frac{D(V_{in} - V_{ds}) - D'V_d}{1 + r_L/R_L}, \quad (1)$$

where V_{ds} is the drain-to-source voltage of the MOS transistor used for switching, r_L is the inductor resistance, V_d is the diode voltage drop, D is the ON duty cycle of the control pulse, and D' is the OFF duty cycle of the pulse.

The inductor L and the smoothing capacitor C_0 will average the pulses passing through Q1 causing ripples on the load. The ripple voltage will be affected by the duty cycle, the switching frequency, the inductance, the internal resistance of

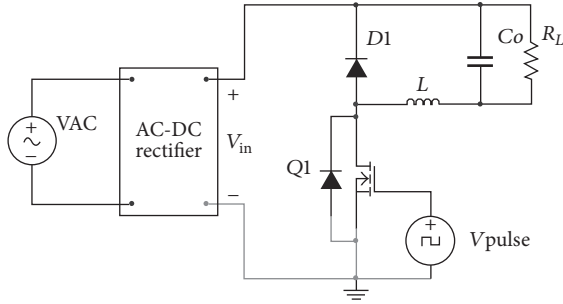

FIGURE 1: Buck DC-DC converter.

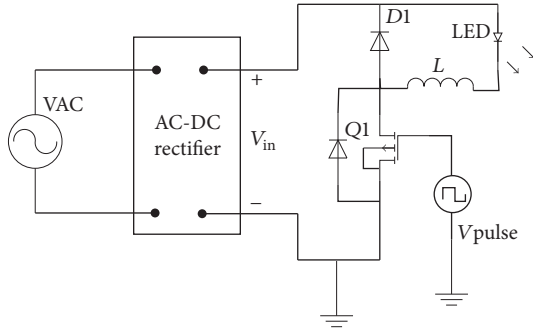

FIGURE 2: The proposed capacitor-less buck DC-DC converter.

the smoothing capacitor ESR, and the value of the smoothing capacitor.

The approximate voltage ripples assuming linear models and a small ripple voltage are given by [10]

$$\Delta V_r = \frac{V_{in} - (V_o + V_{ds} + V_{rL})}{Lf_s} \times D \left(\frac{1}{8C_o f_s} + \text{ESR} \right), \quad (2)$$

where f_s is the switch frequency of V_{pulse} , L is the inductor, V_{rL} is the voltage across the inductor resistance, and ESR is the capacitor series resistor.

The proposed design is a modified version of the design in Figure 1 and is shown in Figure 2, where the load is an array of LEDs, as it is the case in all commercially available LED lamps. The internal capacitance of the LED array will act as a smoothing capacitor if a proper switching frequency and duty cycle are chosen, and hence no external smoothing capacitor is needed.

3. Mathematical Analysis and Experimental Results

3.1. Mathematical Analysis. It is well known that the LED in conduction mode can be modeled using a resistor and an ideal diode for DC mode and a capacitor and a resistor in parallel for AC mode as shown in Figures 3(a) and 3(b), respectively. The resistance r_s represents the constant series contact resistance and quasineutral region resistance of the LED, r_d represents the small signal resistance of the LED at certain DC current, and C_d represents the diffusion

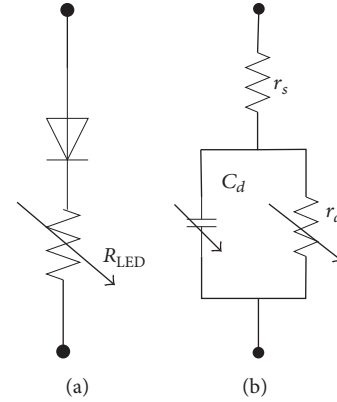
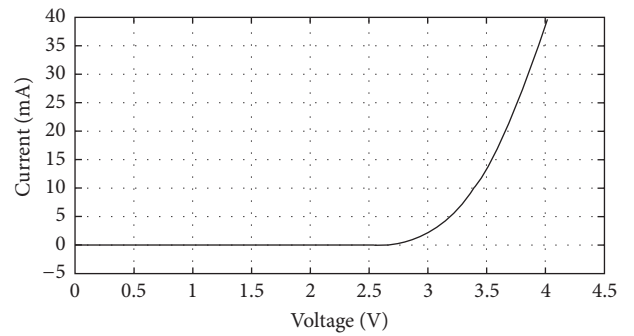

FIGURE 3: LED model in conduction mode for (a) DC mode and (b) AC mode.

FIGURE 4: The V - I characteristics curve of a single white LED.

capacitance at a certain DC current. In conduction mode, r_d is the reciprocal of the conductance which is equal to the DC current divided by the thermal voltage. This indicates that as the DC current increases, the value of the resistance r_d will decrease. Moreover, the value of C_d also is a function of the conductance and its value will increase as the current increases [11].

With reference to Figure 2, the DC output voltage across the LEDs is the same as in (1) with R_L replaced by R_{LED} . The LED equivalent circuits shown in Figure 3 are used in this analysis. The DC output voltage is given by

$$V_{O(DC)} = \frac{D(V_{in} - V_{ds}) - D'V_d}{1 + r_L/R_{LED}}, \quad (3)$$

where r_L is inductor resistance. The value of R_{LED} depends on the current passing through the LED, and it can be deduced from the I - V characteristics curve of the LED shown in Figure 4. It is clear from Figure 4 that as the current increases, the value of R_{LED} will decrease.

To find the effective capacitance of the LED, the ripple current is given by

$$\Delta I_{pp} = \frac{V_{in} - (V_o + V_{ds} + V_{rL})}{Lf_s} \times D, \quad (4)$$

where ΔI_{pp} is the ripple current through the inductor L . From Figure 2 and the model of Figure 3, the output voltage ripple

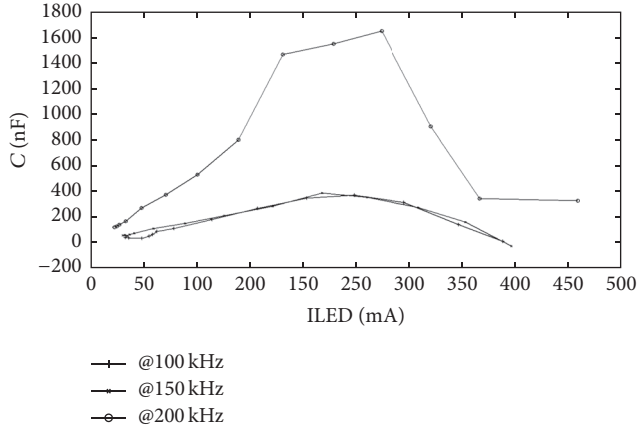
FIGURE 5: Plot of the effective capacitance C_d versus the load current.

is given by

$$\Delta V_r = \Delta I_{pp} \times R_{LOAD} = \Delta I_{pp} (z + r_s), \quad (5)$$

where $z = (r_d \times 1/8f_s C_d)/(r_d + 1/8f_s C_d) = r_d/(1 + 8r_d f_s C_d)$ and $1/8f_s C_d$ is the impedance of the diffusion capacitor [10].

Combining (4) and (5), the output voltage ripple is given by

$$\Delta V_r = \Delta I_{pp} \left(r_s + \frac{1}{g_d + 8f_s C_d} \right), \quad (6)$$

where $g_d = 1/r_d$.

Rewriting (6) to find the effective capacitance C_d ,

$$C_d = \frac{1}{8f_s} \left(\frac{1}{\Delta V_r / \Delta I_{pp} - r_s} - g_d \right). \quad (7)$$

Plots of the effective capacitance as a function of the LED current for different frequencies are shown in Figure 5. It is evident from the figure that the effective capacitance at 200 kHz is high since the impedance of the capacitance is much smaller than that of the dynamic resistance.

In the AC model of Figure 3, the behavior of r_d and C_d gives an indication that as the DC current increases, the ripple voltage will decrease, which is another parameter that can be controlled and affect the ripple voltage. This fact is supported by the experimental results we have carried out and it is explained in the next section.

It is important to point out that the value of C_d is linearly changing with the DC current only in strong conduction mode [12]. However, during the OFF period in the switching buck converter pulse, the LED internal resistance will draw the stored charge and the output voltage will decrease. If the OFF period is long enough, the value of the diffusion capacitor will be very small causing a sharp drop in the output voltage that might cause flicker in the LED light.

3.2. Experimental Results. The circuit shown in Figure 2 was connected in the laboratory using off-the-shelf components to test the proposed design experimentally. The LED used is the sum of 3 series packages of 11 parallel LEDs per

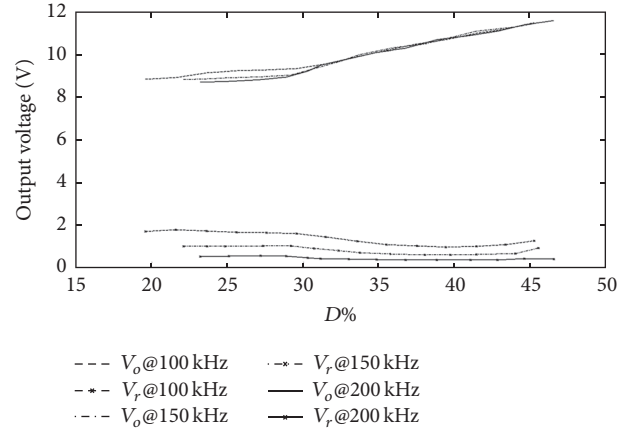
FIGURE 6: The output DC (V_o) and ripple (V_r) voltage versus the duty cycle for different frequencies.

package giving a total of 33 LEDs. The output voltage is measured across the LED packages. The components used are as follows: L is an inductor of 470 μH , $Q1$ is an N-MOS power transistor BUZ71, V_{pulse} is the switching control pulse with an amplitude of 10 V, and $D1$ is a silicon fast switching diode 1N914. The inductor's series resistance was measured and its value was approximately 4 Ω . It was assumed that the AC source was rectified and provided a DC output called V_{in} with nominal voltage of 35 V. The LED's I - V characteristics shown in Figure 4 have been used to extract the value of R_{LED} for different DC current values.

The behavior of the circuit was studied by varying the duty cycle of V_{pulse} from 18% to 44% at three different frequencies (100 kHz, 150 kHz, and 200 kHz). The maximum duty cycle was set to 44% because this duty cycle will produce the maximum LED current. The DC output and ripple voltage are plotted in Figure 6. As is clear from the figure, as the duty cycle increases, the DC output voltage increases. The ripple voltage decreased with the increase in frequency.

From Figure 6, the DC voltage is changing linearly with the duty cycle for $D > 30\%$. Also, it is clear that, for duty cycle greater than 30%, the error is less than 3%. The deviation between theoretical and experimental results is shown in Figure 7. It is evident from the plot that a designer should select the switching pulse duty cycle to be greater than 30% to minimize the error and a higher frequency to minimize the ripple voltage.

If the voltage across the LED reached below a certain value, there will be no diffusion capacitor, and the LED's voltage will drop logarithmically, causing the large error shown in Figure 7. This value can be estimated from the knees of each curve and depends on the forward current as well, since it depends on how deep the LED is in the conduction region. Figures 8 and 9 show the ripple voltage at 100 kHz with duty cycle of 18% and 40%, respectively. The nonlinearity is clearly shown in Figure 8, where the OFF period was long enough to drive the LED to the weak conduction region while the ripple of Figure 9 is almost linear. It is clear that the ripple is linear for higher duty cycle.

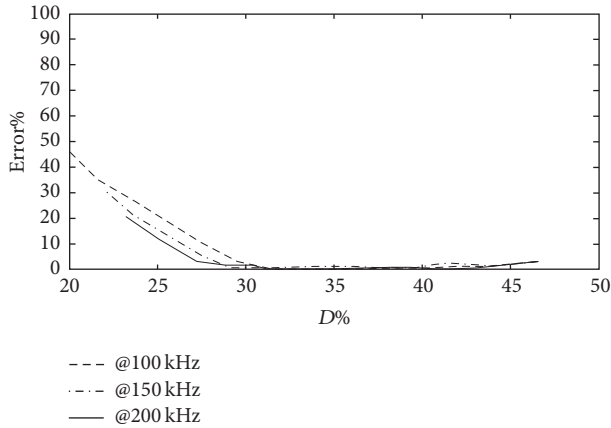

FIGURE 7: The %error in the experimental results with respect to the theory versus the duty cycle.

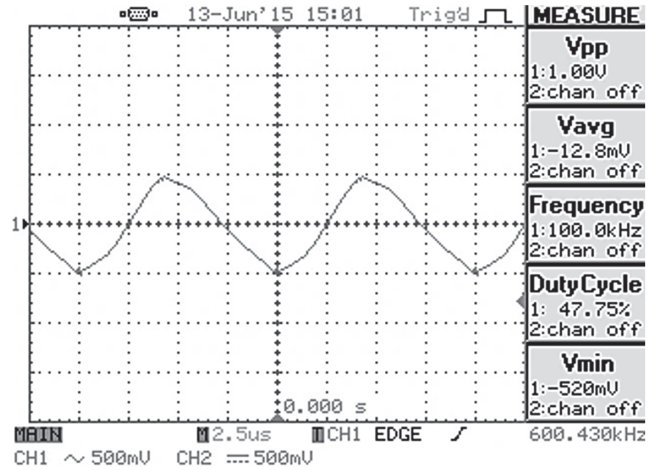

FIGURE 9: Plot of ripple voltage versus time at 100 kHz and $D = 40\%$.

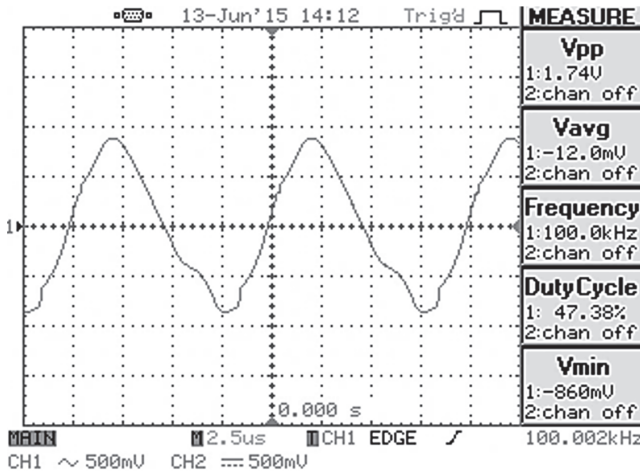

FIGURE 8: Plot of ripple voltage versus time at 100 kHz and $D = 18\%$.

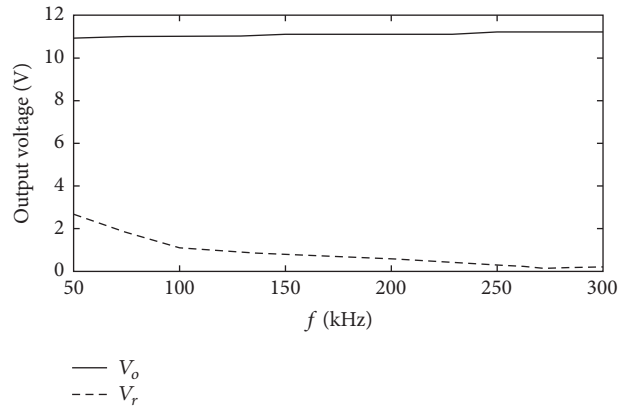

FIGURE 10: The output DC (V_o) and ripple (V_r) voltage versus frequency.

To investigate the changes on the DC output voltages and ripple, the frequency was swept from 50 kHz to 300 kHz at a fixed duty cycle of 40%, and the output was probed. The result is shown in Figure 10. It is clear that the ripple voltage is decreasing as the frequency increases and the DC voltage is almost constant. The minimum ratio of ripple voltage to DC voltage is around 1.4% and it can be decreased further by increasing the frequency.

Efficiency is an important factor in a LED driver. The efficiency was found by measuring the DC output voltage, the output current, the DC input voltage, and the input current for each duty cycle for different frequencies. Experimental results displayed in Figure 11 show that the average efficiency is 85%. The efficiency can be further improved using an inductor with smaller internal resistance and a transistor with smaller ON resistance.

Because of the slight changes in the DC output voltage, the efficiency is barely changing with the change of the frequency, as shown in Figure 12. The average of the efficiency over the frequency range was about 88%. Increasing the frequency further will lead to smaller ripple voltages and smaller components for better integration. However, increasing the

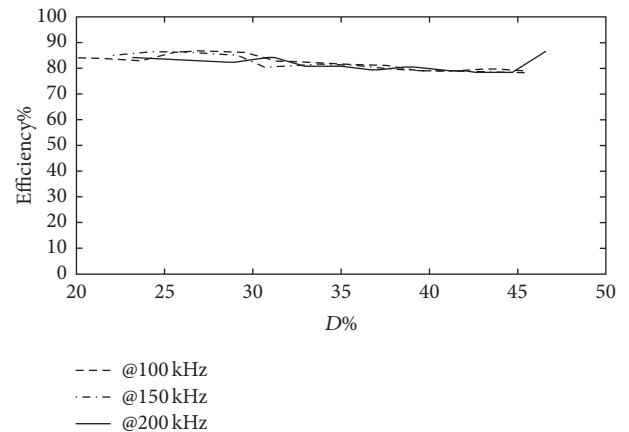

FIGURE 11: The efficiency versus the duty cycle at different frequencies.

switching frequency will reduce the efficiency of the drive because of the switching power loss for light loads [12]. As for LED lighting applications, the LED load needs to draw high current specially when using a capacitor-less drive. This is because it is better to use many parallel LEDs for higher

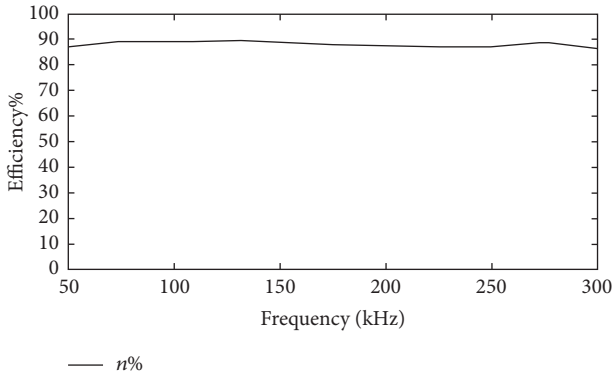

FIGURE 12: The efficiency versus frequency.

summation of LED capacitance, which gives this method one more advantage.

4. Conclusion

A new approach to designing capacitor-less buck DC-DC converter was developed and tested. The proposed single switch circuit is able to reduce the ripple in a compact form and can be extended to any other LED configuration. The design's mathematical model was developed based on experimental verification. The efficiency of the driver is 85% and we expect the lifetime to be much higher than existing drives, as there is no capacitor in the switching path of the driver.

Competing Interests

The authors declare that they have no competing interests.

Acknowledgments

The authors would like to thank King Abdulaziz City for Science and Technology for financial support (Project no. A-T-34-20) and KFUPM for using all facilities to carry out this research.

References

- [1] B. Wang, X. Ruan, K. Yao, and M. Xu, "A method of reducing the peak-to-average ratio of LED current for electrolytic capacitor-less AC-DC drivers," *IEEE Transactions on Power Electronics*, vol. 25, no. 3, pp. 592–601, 2010.
- [2] S. Wang, X. Ruan, K. Yao, S.-C. Tan, Y. Yang, and Z. Ye, "A flicker-free electrolytic capacitor-less AC-DC LED driver," *IEEE Transactions on Power Electronics*, vol. 27, no. 11, pp. 4540–4548, 2012.
- [3] W. Chen and S. Y. R. Hui, "Elimination of an electrolytic capacitor in AC/DC light-emitting diode (LED) driver with high input power factor and constant output current," *IEEE Transactions on Power Electronics*, vol. 27, no. 3, pp. 1598–1607, 2012.
- [4] P. S. Almeida, G. M. Soares, D. P. Pinto, and H. A. C. Braga, "Integrated SEPIC buck-boost converter as an off-line LED driver without electrolytic capacitors," in *Proceedings of the 38th Annual Conference on IEEE Industrial Electronics Society (IECON '12)*, pp. 4551–4556, Québec, Canada, October 2012.
- [5] H. Ma, J.-S. Lai, Q. Feng, W. Yu, C. Zheng, and Z. Zhao, "A novel valley-fill SEPIC-derived power supply without electrolytic capacitor for LED lighting application," *IEEE Transactions on Power Electronics*, vol. 27, no. 6, pp. 3057–3071, 2012.
- [6] H. Ma, W. Yu, C. Zheng, Q. Feng, and B. Chen, "A universal input high-power-factor PFC pre-regulator without electrolytic capacitor for PWM dimming LED lighting application," in *Proceedings of the IEEE Energy Conversion Congress and Exposition (ECCE '11)*, pp. 2288–2295, September 2011.
- [7] M. Ryu, J. Kim, J. Baek, and H.-G. Kim, "New multi-channel LEDs driving methods using current transformer in electrolytic capacitor-less AC-DC drivers," in *Proceedings of the 27th Annual IEEE Applied Power Electronics Conference and Exposition (APEC '12)*, pp. 2361–2367, Orlando, Fla, USA, February 2012.
- [8] J. C. W. Lam and P. K. Jain, "A high power factor, electrolytic capacitor-less AC-input LED driver topology with high frequency pulsating output current," *IEEE Transactions on Power Electronics*, vol. 30, no. 2, pp. 943–955, 2015.
- [9] M. A. Al-Absi, Z. J. Khalifa, and A. E. Hussein, "A new capacitor-less LED drive," in *Proceedings of the 13th International Multi-Conference on Systems, Signals and Devices (SSD '16)*, pp. 354–357, IEEE, Leipzig, Germany, March 2016.
- [10] W. Robert and M. Dragan, *Fundamentals of Power Electronics*, vol. 2nd, Kluwer Academic, New York, NY, USA, 2001.
- [11] F. Robert, *Semiconductor Device Fundamentals*, Addison-Wesley, New York, NY, USA, 1996.
- [12] L. Solymar, D. Walsh, and A. Syms, *Electrical Properties of Materials*, 9th edition, 2014.

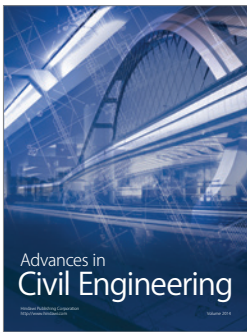
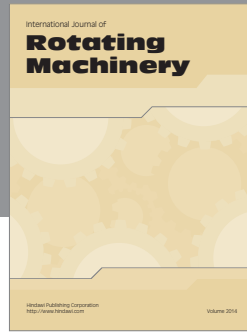

Hindawi

Submit your manuscripts at
<https://www.hindawi.com>

