

## Review Article

# Complications of Radical Cystectomy and Orthotopic Reconstruction

Wei Shen Tan,<sup>1,2</sup> Benjamin W. Lamb,<sup>2</sup> and John D. Kelly<sup>1,2</sup>

<sup>1</sup>*Division of Surgery and Interventional Science, UCL Medical School, University College London, 74 Huntley Street, London WC1E 6AU, UK*

<sup>2</sup>*Department of Urology, University College London Hospital, 16-18 Westmoreland Street, London W1B 8PH, UK*

Correspondence should be addressed to Wei Shen Tan; [tanweishen@hotmail.com](mailto:tanweishen@hotmail.com)

Received 31 July 2015; Revised 26 October 2015; Accepted 11 November 2015

Academic Editor: Fabio Campodonico

Copyright © 2015 Wei Shen Tan et al. This is an open access article distributed under the Creative Commons Attribution License, which permits unrestricted use, distribution, and reproduction in any medium, provided the original work is properly cited.

Radical cystectomy and orthotopic reconstruction significant morbidity and mortality despite advances in minimal invasive and robotic technology. In this review, we will discuss early and late complications, as well as describe efforts to minimize morbidity and mortality, with a focus on ileal orthotopic bladder substitute (OBS). We summarise efforts to minimize morbidity and mortality including enhanced recovery as well as early and late complications seen after radical cystectomy and OBS. Centralisation of complex cancer services in the UK has led to a fall in mortality and high volume institutions have a significantly lower rate of 30-day mortality compared to low volume institutions. Enhanced recovery pathways have resulted in shorter length of hospital stay and potentially a reduction in morbidity. Early complications of radical cystectomy occur as a direct result of the surgery itself while late complications, which can occur even after 10 years after surgery, are due to urinary diversion. OBS represents the ideal urinary diversion for patients without contraindications. However, all patients with OBS should have regular long term follow-up for oncological surveillance and to identify complications should they arise.

## 1. Introduction

Radical cystectomy remains the gold standard for treatment of patients with muscle invasive bladder cancer, or recurrent high grade non-muscle invasive bladder cancer. Despite the advent of minimally invasive and robotic technology, radical cystectomy has a significant mortality and morbidity. Ninety-day mortality rates from population studies range from 5.1% to 8.1%, [1, 2] which are high for surgery with curative intent. Morbidity is also significant, with 90-day complication rate between 28%–64%, even in high volume centres [3–5]. The high rates of morbidity and mortality reflect the fact that the majority of patients undergoing this procedure are elderly patients with multiple comorbidities.

In this review, we will discuss early and late complications, as well as describing efforts to minimize morbidity and mortality, with a focus on ileal orthotopic bladder substitute (OBS).

## 2. Minimizing Morbidity and Mortality

In the United States, an analysis of 35,055 cases from the National Cancer Database reported 30-day and 90-day operative mortality rates of 3.2% and 8.0% for radical cystectomy in low-volume centers and 2.7% and 7.2% in high-volume institutions, respectively [6]. The volume-outcome relationship for radical cystectomy is apparent in the literature, with high concordance between high volume centres showing a reduction in mortality by as much as 37% at 30 days [7]. Within the UK, a restructuring of the organisation of cancer surgery has resulted in the centralization of radical cystectomy surgery [8] which has been associated with a fall in 90-day mortality from 10.3 to 5.1%, with the greatest benefit seen in patients  $\geq 70$  years of age [9]. Reduction in mortality within high volume centres is related to a reduction in “failure-to-rescue” events following complex surgery and suggests that the perioperative management of patients undergoing radical

cystectomy is critical in improving mortality and morbidity in this group [10].

### 3. Enhanced Recovery

The enhanced recovery program (ERP) has been shown to reduce the occurrence of adverse events and length of stay for patients undergoing abdominal surgery across a number of disciplines [11]. In some high volume institutions, the introduction of ERP has resulted in a reduction in the median length of stay from 8 to 4 days [12].

Prior to surgery, carbohydrate loading is recommended to minimize the development of insulin resistance and catabolism of protein and fat stores secondary to the physiological stress response seen in patients undergoing surgery [13]. Other features of enhanced recovery used for patients undergoing radical cystectomy include the avoidance of bowel preparation, immediate removal of nasogastric tube after surgery, and the early commencement of oral intake [14].

Postoperative ileus is the most frequent reason for prolonged hospital stay following cystectomy [16]. To reduce the risk of ileus, prokinetics such as metoclopramide should be used postoperatively, and systemic opioid analgesia should be reserved for breakthrough pain. Regular analgesia should consist of acetaminophen and nonsteroidal anti-inflammatories. Additionally, a randomized controlled trial has shown that Alvimopan, a peripherally acting  $\mu$  receptor opioid antagonist, significantly reduces time to bowel movement in patients undergoing radical cystectomy [17]. In a systemic review and meta-analysis, chewing sugar-free gum has also been shown to reduce time to flatus, bowel movement and hospital length of stay in patients undergoing bowel surgery [18].

### 4. Early Complications

The modified Memorial Sloan-Kettering Cancer Centre (MSKCC) Clavien system was developed in an effort to standardize the reporting of early complications (Table 1) [4]. The majority of early complications following open radical cystectomy and OBS reconstruction occur as a direct result of the surgery and include gastrointestinal (29%), infection (25%), and wound-related complications (15%) [4]. Multivariate analysis has shown age, prior abdominal or pelvic surgery, ASA > 2 and estimated blood loss as independent predictors of high grade complications [4]. However, high grade complications rates between continent and incontinent diversions were comparable [4, 19].

Intestinal anastomotic leak is rare. However, urinary leakage is more common in the early postoperative period and particular attention should be paid to the constructed diversion to safeguard against this. A prospective randomized controlled trial showed that the use of stents of the ureteroileal anastomosis resulted in a lower rate of urinary leak [20]. Ureteral stents can be externalised for urinary monitoring and easy removal. Alternatively double J stents can be left *in situ* or tied to the urethral catheter for removal after 7–9 days. In our practice, routine daily aspiration and flushing of the pouch with 0.9% saline are essential in the

TABLE 1: Early and late complications of radical cystectomy with OBS reconstruction.

Early complications	Late complications
Genitourinary	Urinary tract infection
Gastrointestinal	Gastrointestinal-bowel obstruction
Infections	Afferent limb stenosis
Wound	Urethral stricture
Cardiac	Stones
Pulmonary	Incontinence/retention
Thromboembolic	Metabolic
Neurological	Orthotopic bladder substitute to vaginal fistula (rare)
Surgical	New malignancy

early postoperative phase to prevent build-up of mucous. Although we routinely use a suprapubic catheter, this is not routine in all centres [21]. Intraoperatively, a passive pelvic drain is typically placed close to the anastomoses and removed when the integrity of the anastomosis is deemed intact. A cystogram typically at three weeks should be performed prior to the removal of the catheter to check for OBS leak.

The majority of urinary leaks can be managed conservatively. If necessary, percutaneous drainage or bilateral nephrostomies to divert urine flow might be necessary in nondraining leaks. The incidence of urinary leak in OBS formation is theoretically higher due to a longer suture line compared to an ileal conduit.

Infection is the second most common perioperative complication. A short course of prophylactic broad spectrum antibiotics such as a second- or third-generation cephalosporins that cover skin, respiratory, urinary, and gastrointestinal organisms is routinely prescribed to reduce the incidence of infection [22]. Adequate analgesia, chest physiotherapy, and early mobilization can help reduce atelectasis and subsequent chest infection. Wound related complications are more common in open cystectomy where a limited laparotomy wound can become infected. Other wound complications include dehiscence or incisional hernia, although these are less frequently observed.

Deep vein thrombosis (DVT) is a recognized serious postoperative complication affecting up to 4.7% of radical cystectomy patients [23]. Analysis from data from the US National Surgical Quality Improvement Programme showed that age, operative time, sepsis, and hospital length of stay are independent predictors for DVT development on multivariate analysis [24]. Fifty-eight percent of patients who developed DVT did so after discharge from hospital [23]. Hence, thromboprophylaxis with low molecular weight heparin is recommended for up to four weeks after cystectomy [22].

### 5. Late Complications

Patients undergoing OBS may continue to develop complications even up to 10 years after surgery [25]. These

complications include urinary tract infection, deterioration in renal function, calculi formation, metabolic complications, voiding dysfunction, and recurrence of disease.

**5.1. Urinary Tract Infection.** The presence of leucocytes and bacteria is commonly seen in urine culture of patients with OBS. This is not surprising given that the intestinal segments which are used to form OBS are heavily colonized by bacteria. Up to 78% of urine cultures in patients with OBS are positive for bacteria [26, 27]. However, despite the bacteria seen, the majority of patients are asymptomatic and have normal inflammatory markers. However, it has been suggested that 58% of patients with asymptomatic bacteriuria will develop a UTI and 18% will present with urosepsis in a 5-year period [27]. It is currently recommended that, in the absence of symptoms of UTI, OBS patients with bacteriuria should not be treated with antibiotics (in order to prevent drug resistance), although there might be a role for prophylactic antibiotics in those with recurrent UTI.

**5.2. Deterioration in Renal Function.** There are two main factors following OBS that are thought to play a role in deterioration of patients' renal function:

- (1) Hydronephrosis secondary to ureteroileal strictures.
- (2) Reflux of infected urine.

High pressure reflux of infected urine can cause renal function deterioration over time. However, the use of antireflux techniques in ileal OBS is debatable. In a randomized trial, Studer et al. showed that there was no significant difference in serum creatinine, urine infection rates, and bladder capacity between the antireflux nipple valve and a refluxing anastomosis [28]. However, upper tract dilatation due to ureteroileal stenosis was seen in 13.5% of patients with antireflux nipple compared to 3% of patients with the refluxing technique [28]. A recent randomized controlled trial between the T pouch and Studer pouch has shown no difference in postoperative renal function or risk of urinary tract infection at three years' follow-up [29]. However, patients with T pouch had a much higher rate of stenosis at the ureteroileal anastomosis and afferent limb which required surgical intervention.

Most ureteroileal stenoses can be treated endoscopically, normally with balloon dilatation, stenting, or incision, while approximately one in three patients requires open surgery. Another randomized trial comparing ileal or colonic OBS (with or without antireflux technique) and caecal OBS with antireflux implantation showed a fall in glomerular filtration rate (GFR) in all three groups, which were not significantly different after more than 10 years' follow-up [30]. Today, most OBS reconstructions by open or intracorporeal robotic techniques involve refluxing ureteroileal anastomosis [31–33]. As long as the principles of detubularised bowel and a spherical reservoir of sufficient volume are met, intraluminal pressure should be low and refluxing ureters should not compromise renal function. Median follow-up of 10.5 years reports no significant difference in renal function decline between OBS patients with freely refluxing ureteroileal anastomosis and ileal conduit [34].

**5.3. Calculi Formation.** OBS calculi formation has an incidence of 0.5%–8.1% depending on technique used for construction [25, 35]. Stone formation is multifactorial with poor bladder emptying and urinary stasis the main risk factors. Hypocitraturia due to increase in renal calcium and hydrogen ion excretion and hyperoxaluria due to malabsorption predispose to the formation of calcium oxalate and calcium phosphate calculi, respectively. Recurrent proteus infections due to colonization of the OBS with gut bacteria can result in struvite stone formation [26].

Traditionally, OBS were constructed using soluble sutures as the presence of foreign materials was observed to act as a nucleus for stone formation. However, the use of newer titanium stapling devices, which allow for faster and easier bladder reconstruction, have been reported to be resistant to encrustation with a stone rate of 9.2% during a median follow-up of 41 months which is still higher than some conventional series [25, 36]. The majority of stones can be managed via an endoscopic approach although percutaneous and laparoscopic approaches are sometimes necessary [37].

**5.4. Metabolic Complications.** The metabolic consequences of OBS formation are dependent on the type, position, and length of bowel used. They are more commonly seen in OBS than in ileal conduit due to the longer contact time of urine with bowel mucosa. The use of more proximal intestinal segments such as jejunum results in significantly more metabolic abnormalities due to a larger total surface area as a result of more villi. In addition, colonic mucosa has more efficient tight junctions which prevent significant osmotic shifts of water compared to either ileum or jejunum. We will focus on metabolic abnormalities in ileal OBS.

The key driver for metabolic acidosis is the absorption of ammonia ( $\text{NH}_4^-$ ) from urine [38]. As shown in Figure 1,  $\text{NH}_4^-$  is converted into ammonium ( $\text{NH}_3$ ) and free hydrogen ions ( $\text{H}^+$ ) in the intestinal luminal cells. This results in the accumulation of excess hydrogen ions and metabolic acidosis. In addition, chloride ( $\text{Cl}^-$ ) is absorbed while bicarbonate ( $\text{HCO}_3^-$ ) is secreted.

The presence of hypoosmolar urine in the OBS results in the secretion of sodium ( $\text{Na}^+$ ) from the OBS into the urine in exchange for  $\text{H}^+$  ions, further promoting metabolic acidosis. Hyponatremia occurs, which results in aldosterone secretion leading to increased absorption of  $\text{Na}^+$  and secretion of potassium ( $\text{K}^+$ ) by the renal collecting tubules. Hypokalaemia is further exacerbated by ileal secretion of  $\text{K}^+$ . A fluid shift accompanies the movement of solute resulting in a salt depleting, hypovolemic state, which is most apparent during the weaning period from intravenous fluid to oral fluids. The net result is a hypokalaemic hyperchloremic metabolic acidosis [39].

This subclinical acidosis is normally compensated well by patients with normal renal function. However, in severe cases patients might present with fatigue, nausea, and vomiting. The majority of patients with symptomatic acidosis require treatment with sodium bicarbonate (1–2 g three times daily) for the first 6 weeks at least after catheter removal. Patients should also be encouraged to drink a minimum of 2–3 L of fluids per day to prevent dehydration. Other electrolyte

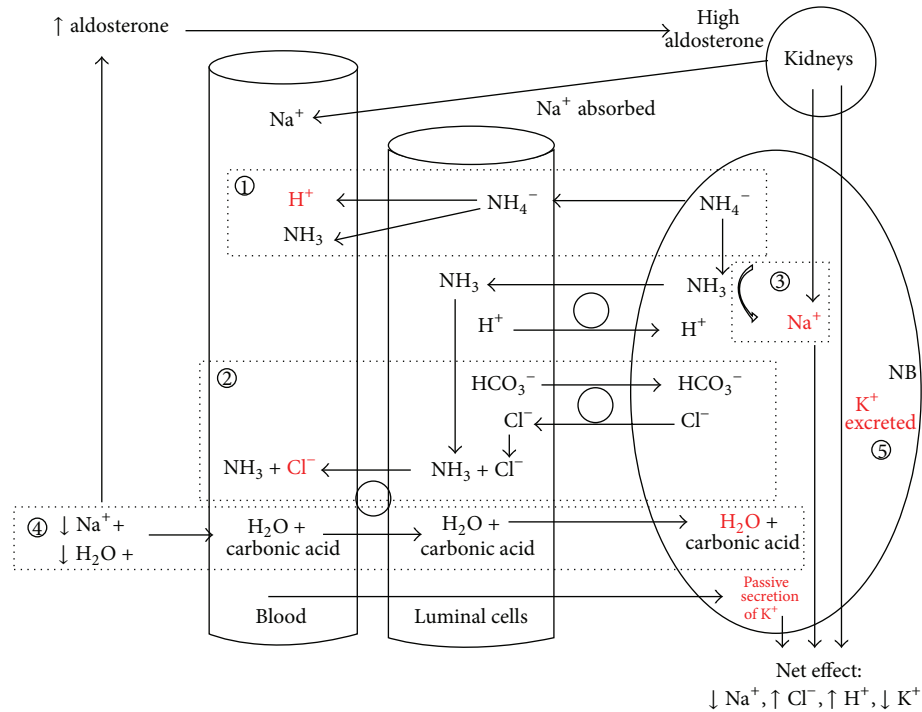

FIGURE 1: Electrolyte abnormalities in patients with ileal and/or colonic OBS. (1)  $\text{NH}_4^-$  absorption from urine which dissociates to  $\text{H}^+$  and  $\text{NH}_3$  resulting in metabolic acidosis. (2)  $\text{Cl}^-$  is exchanged with  $\text{HCO}_3^-$  and transported into blood. (3)  $\text{Na}^+$  is displaced by  $\text{NH}_4^-$  and not absorbed by bowel resulting in a net loss. (4) There is a net loss of  $\text{H}_2\text{O}$  resulting in dehydration and loss of  $\text{Na}^+$  due to NB secretion of  $\text{Na}^+$  into urine. (5) Elevated aldosterone levels due to  $\text{Na}^+$  loss precipitates  $\text{K}^+$  loss from renal tubules.  $\text{Na}^+$ : sodium;  $\text{K}^+$ : potassium;  $\text{NH}_4^-$ : ammonium;  $\text{NH}_3$ : ammonia;  $\text{HCO}_3^-$ : bicarbonate;  $\text{H}^+$ : hydrogen;  $\text{H}_2\text{O}$ : water;  $\text{Cl}^-$ : chloride; NB: neobladder.

abnormalities can include hypomagnesemia and hypocalcaemia.

Resection up to 60 cm of ileum is generally safe and should not lead to malabsorption although Vitamin B12 deficiency can occur if a longer segment is used, especially if the terminal ileum is utilised, and may require parenteral replacement of Vitamin B12 [40]. Malabsorption of bile salts secondary to resection of the terminal ileum can result in diarrhoea, giving rise to dehydration as well as promoting the formation of oxalate containing renal calculi. Increased reabsorption of urinary ammonia can lead to hyperammonemic encephalopathy and abnormal drug metabolism especially if hepatic function is impaired. Chronic metabolic acidosis promotes the demineralization bone with the release of calcium carbonate and phosphate [41]. Demineralisation leads to osteomalacia and hyperphosphatemia which stimulates urinary phosphate stone formation.

**5.5. Incontinence.** Many factors influence continence following OBS reconstruction. A functionally intact sphincter that can generate a resistance pressure in excess of intraluminal OBS pressure is essential. Other factors such as patient age, urethral length, sphincter innervation, bladder capacity, the type of bowel segment used, and the ability to completely empty ones bladder emptying can all affect continence. In addition, it is essential to make a distinction between daytime and nocturnal continence, as they have different aetiology.

Analysis of daytime continence rates by Hautmann et al. reports that up to 85–90% of patients report using between one or no pads in a 24-hour period one year after continent diversion [42]. Multivariate analysis has shown that patients aged below 65 years and those treated with radical cystoprostatectomy with nerve sparing techniques had significantly better daytime continence [43]. Other factors include use of colonic segments and decrease in functional urethral length. Continence rates for most patients continue to improve up to 6 to 12 months as the OBS capacity increases. Treatment options for those with persisting severe incontinence may include periurethral collagen injection, a urethral sling, or an artificial urinary sphincter.

It may take patients up to 24 months to regain nocturnal continence as the OBS capacity increases. Analysis of the literature by Hautmann et al. reported that 20% to 30% of patients with OBS reconstruction suffer from nocturnal incontinence [42]. Loss of nocturnal continence is due to the absence of the neurogenic feedback, the sphincter detrusor reflex, and decrease in nocturnal sphincter tone. Multivariate analysis found that large postvoid residual volume, frequency, and amplitude of contractions of the ileal segment were independently associated with nocturnal incontinence [44]. Patients who have nocturnal enuresis are advised to void before going to bed, avoid alcohol and hypnotics in the evening, and set an alarm clock to wake up at least once at night to void. Patients treated with imipramine hydrochloride

TABLE 2: Recommended follow-up regime by European Association of Urology. Adapted from Stenzl et al. [15].

	Months after cystectomy								
	3	6	12	18	24	30	36	48	60
$\leq$ pT1									
Ultrasound kidneys	X	—	—	—	—	—	—	—	—
CT chest + CT intravenous urography	—	—	X	—	X	—	X	X	X
Blood test + mid-stream urine culture + urine cytology	X	X	X	—	X	—	X	X	X
pT2									
Ultrasound kidneys	X	—	—	—	—	—	—	—	—
CT chest + CT intravenous urography	—	X	X	X	X	—	X	X	X
Blood test + mid-stream urine culture + urine cytology	X	X	X	—	X	—	X	X	X
$\geq$ pT3 +/- N+									
Ultrasound kidneys	X	—	—	—	—	—	—	—	—
CT chest + CT intravenous urography	X	X	X	X	X	X	X	X	X
Blood test + mid stream urine culture + urine cytology	X	X	X	—	X	X	X	X	X

have reported decrease of incontinence rates by 25% [44]. A prospective crossover study showed that oxybutynin and verapamil improved nocturnal incontinence by 70% and 55%, respectively [45].

In summary, continence following OBS construction can be optimised by the use of detubularised ileum, of sufficient length and construction technique to give a large capacity, preservation of urethral sphincter function through nerve sparing techniques, and maximising urethral length.

**5.6. Urinary Retention.** Voiding in patients with OBS requires both the pelvic floor to relax and a simultaneous increase in intra-abdominal pressure which is best achieved in a sitting position. Occasionally, the use of manual pressure to the suprapubic area and bending forward while sitting may facilitate voiding. Urinary retention is more common in women with 43% of women compared to 20% of men requiring intermittent catheterization [35]. Video urodynamics show that, in women, the OBS falls into the pelvic cavity resulting in mechanical obstruction due to kinking of the OBS-urethral junction [46]. Hence, it has been suggested that in female patients packing of the posterior pelvis coupled with an anterior superior fixation of the OBS might reduce the incidence of urinary retention. Other proposed techniques include sacrocolpopexy with mesh and omental packing between the vagina and bladder [47] or suturing the OBS at the dome to the rectus muscles with posterior packing of the pouch and fixing the peritoneum of the rectum to the vaginal stump [46].

All patients with suspected urinary retention should be evaluated to exclude urethra or ureteroileal anastomosis stricture. The main risk factors for urinary retention after OBS reconstruction are a large capacity OBS due to excessive bowel segment length and nonnerve sparing techniques. Patients are therefore advised to empty their OBS at regular intervals to prevent the development of an atonic pouch.

Treatment for urinary retention is intermittent self-catheterization, and all patients should be counselled about this preoperatively. Alpha blockers are unfortunately not effective [46].

**5.7. Long Term Follow-Up.** Follow-up should be risk adapted and patients with high risk of recurrence such as extravesical disease, positive lymph node status, positive surgical margins, multifocal tumour, and urethral tumour should be reviewed more regularly [48].

Early follow-up (4 months) is essential to recognize ureteroileal strictures. From 4–60 months oncological surveillance is the primary concern, which is normally performed using CT scans. The majority of tumour recurrences occur within two years of surgery [49]. Although most early recurrences are asymptomatic, symptoms suggesting recurrence include pain, haematuria, urinary retention, flank pain, and palpable mass [49]. Long term follow-up (more than 5 years) is required to identify renal/OBS calculi and recurrence of urethral or upper tract transitional cell carcinoma. In addition to routine blood test such as full blood count, renal function, and electrolyte, liver function test and bone profile, bicarbonate, chloride, Vitamin B12, and folate should also be performed.

Urethral recurrence has been observed in 5.6% of patients undergoing RC at a median follow-up of 13.3 months [50]. Common sites of distal recurrence include lung, liver, and bones. Table 2 describes the European Association of Urology (EAU) recommendation for a risk adopted surveillance protocol [15]. MRI is an alternative in patients for whom CT scans are contraindicated due to impaired renal function or contrast allergy. Patients not at high risk and with no clinical suspicion of upper tract recurrence do not routinely need upper tract imaging [48]. The ICUD-EAU Consultation in Bladder Cancer does not recommend the routine use of urinary cytology, urethral washing, and urethroscopy in asymptomatic patients, although they are routinely performed in some centres [48].

## 6. Conclusion

Radical cystectomy with OBS reconstruction is a challenging procedure that carries a significant risk of short and long term complications. The technique is gaining popularity and should be offered to patients in the absence of absolute

contraindications whilst taking into account oncological and patient factors. It is important to manage patient's expectations and ensure that they are committed and fully engaged during the postoperative period. Ileal OBS with freely refluxing ureteroileal anastomosis is most commonly performed and although many techniques exist, no one technique is considered superior. Robotic assisted radical cystectomy is gaining popularity, and although technically challenging intracorporeal OBS reconstruction is routinely performed in select centres. All patients with OBS reconstruction should have regular long term follow-up for oncological surveillance and to identify complications should they arise.

## Conflict of Interests

The authors declare that there is no conflict of interests regarding the publication of this paper.

## Acknowledgment

The authors are grateful to the UCLH Biomedical Research Centre for funding their work.

## References

- [1] A. S. Zakaria, F. Santos, A. Dragomir, S. Tanguay, W. Kassouf, and A. G. Aprikian, "Postoperative mortality and complications after radical cystectomy for bladder cancer in Quebec: a population-based analysis during the years 2000–2009," *Canadian Urological Association Journal*, vol. 8, no. 7-8, pp. 259–267, 2014.
- [2] L. S. Hounsome, J. Verne, J. S. McGrath, and D. A. Gillatt, "Trends in operative caseload and mortality rates after radical cystectomy for bladder cancer in England for 1998–2010," *European Urology*, vol. 67, no. 6, pp. 1056–1062, 2015.
- [3] J. P. Stein, G. Lieskovsky, R. Cote et al., "Radical cystectomy in the treatment of invasive bladder cancer: long-term results in 1,054 patients," *Journal of Clinical Oncology*, vol. 19, no. 3, pp. 666–675, 2001.
- [4] A. Shabsigh, R. Korets, K. C. Vora et al., "Defining early morbidity of radical cystectomy for patients with bladder cancer using a standardized reporting methodology," *European Urology*, vol. 55, no. 1, pp. 164–176, 2009.
- [5] R. E. Hautmann, R. C. de Petriconi, and B. G. Volkmer, "Lessons learned from 1,000 neobladders: the 90-day complication rate," *The Journal of Urology*, vol. 184, no. 3, pp. 990–994, 2010.
- [6] M. E. Nielsen, K. Mallin, M. A. Weaver et al., "Association of hospital volume with conditional 90-day mortality after cystectomy: an analysis of the National Cancer Data Base," *BJU International*, vol. 114, no. 1, pp. 46–55, 2014.
- [7] J. F. Finks, N. H. Osborne, and J. D. Birkmeyer, "Trends in hospital volume and operative mortality for high-risk surgery," *The New England Journal of Medicine*, vol. 364, no. 22, pp. 2128–2137, 2011.
- [8] T. Powles and J. Kelly, "Innovation: London Cancer—multidisciplinary approach to urological cancer," *Nature Reviews Clinical Oncology*, vol. 10, no. 11, pp. 609–610, 2013.
- [9] L. S. Hounsome, J. Verne, J. S. McGrath, and D. A. Gillatt, "Trends in operative caseload and mortality rates after radical cystectomy for bladder cancer in England for 1998–2010," *European Urology*, vol. 67, no. 6, pp. 1056–1062, 2014.
- [10] A. A. Ghaferi, J. D. Birkmeyer, and J. B. Dimick, "Variation in hospital mortality associated with inpatient surgery," *The New England Journal of Medicine*, vol. 361, no. 14, pp. 1368–1375, 2009.
- [11] H. Kehlet, "Multimodal approach to control postoperative pathophysiology and rehabilitation," *British Journal of Anaesthesia*, vol. 78, no. 5, pp. 606–617, 1997.
- [12] S. Daneshmand, H. Ahmadi, A. K. Schuckman et al., "Enhanced recovery protocol after radical cystectomy for bladder cancer," *The Journal of Urology*, vol. 192, no. 1, pp. 50–55, 2014.
- [13] A. Thorell, J. Nygren, and O. Ljungqvist, "Insulin resistance: a marker of surgical stress," *Current Opinion in Clinical Nutrition and Metabolic Care*, vol. 2, no. 1, pp. 69–78, 1999.
- [14] B. A. Inman, F. Harel, R. Tiguert, L. Lacombe, and Y. Fradet, "Routine nasogastric tubes are not required following cystectomy with urinary diversion: a comparative analysis of 430 patients," *The Journal of Urology*, vol. 170, no. 5, pp. 1888–1891, 2003.
- [15] A. Stenzl, N. C. Cowan, M. De Santis et al., "The updated EAU guidelines on muscle-invasive and metastatic bladder cancer," *European Urology*, vol. 55, no. 4, pp. 815–825, 2009.
- [16] S. S. Chang, R. G. Baumgartner, N. Wells, M. S. Cookson, and J. A. Smith Jr., "Causes of increased hospital stay after radical cystectomy in a clinical pathway setting," *Journal of Urology*, vol. 167, no. 1, pp. 208–211, 2002.
- [17] C. T. Lee, S. S. Chang, A. M. Kamat et al., "Alvimopan accelerates gastrointestinal recovery after radical cystectomy: a multicenter randomized placebo-controlled trial," *European Urology*, vol. 66, no. 2, pp. 265–272, 2014.
- [18] E. J. Noble, R. Harris, K. B. Hosie, S. Thomas, and S. J. Lewis, "Gum chewing reduces postoperative ileus? A systematic review and meta-analysis," *International Journal of Surgery*, vol. 7, no. 2, pp. 100–105, 2009.
- [19] D. J. Parekh, W. B. Gilbert, M. O. Koch, and J. A. Smith Jr., "Continent urinary reconstruction versus ileal conduit: a contemporary single-institution comparison of perioperative morbidity and mortality," *Urology*, vol. 55, no. 6, pp. 852–855, 2000.
- [20] A. Mattei, F. D. Birkhaeuser, C. Baermann, S. H. Warncke, and U. E. Studer, "To stent or not to stent perioperatively the ureteroileal anastomosis of ileal orthotopic bladder substitutes and ileal conduits? Results of a prospective randomized trial," *Journal of Urology*, vol. 179, no. 2, pp. 582–586, 2008.
- [21] J. P. Stein and D. G. Skinner, "Surgical Atlas: the orthotopic T-pouch ileal neobladder," *BJU International*, vol. 98, no. 2, pp. 469–482, 2006.
- [22] Y. Cerantola, M. Valerio, B. Persson et al., "Guidelines for perioperative care after radical cystectomy for bladder cancer: enhanced recovery after surgery (ERAS) society recommendations," *Clinical Nutrition*, vol. 32, no. 6, pp. 879–887, 2013.
- [23] A. J. Sun, H. Djaladat, A. Schuckman, G. Miranda, J. Cai, and S. Daneshmand, "Venous thromboembolism following radical cystectomy: significant predictors, comparison of different anticoagulants and timing of events," *The Journal of Urology*, vol. 193, no. 2, pp. 565–569, 2015.
- [24] A. A. Vandlac, N. G. Cowan, Y. Chen et al., "Timing, incidence and risk factors for venous thromboembolism in patients undergoing radical cystectomy for malignancy: a case for extended duration pharmacological prophylaxis," *Journal of Urology*, vol. 191, no. 4, pp. 943–947, 2014.

- [25] R. E. Hautmann, R. C. de Petriconi, and B. G. Volkmer, "25 years of experience with 1,000 neobladders: long-term complications," *Journal of Urology*, vol. 185, no. 6, pp. 2207–2212, 2011.
- [26] F. Suriano, M. Gallucci, G. P. Flammia et al., "Bacteriuria in patients with an orthotopic ileal neobladder: urinary tract infection or asymptomatic bacteriuria?" *BJU International*, vol. 101, no. 12, pp. 1576–1579, 2008.
- [27] D. P. Wood Jr., F. J. Bianco Jr., J. E. Pontes, M. A. Heath, and D. DaJusta, "Incidence and significance of positive urine cultures in patients with an orthotopic neobladder," *Journal of Urology*, vol. 169, no. 6, pp. 2196–2199, 2003.
- [28] U. E. Studer, H. Danuser, G. N. Thalmann, J. P. Springer, and W. H. Turner, "Antireflux nipples or afferent tubular segments in 70 patients with ileal low pressure bladder substitutes: long-term results of a prospective randomized trial," *The Journal of Urology*, vol. 156, no. 6, pp. 1913–1917, 1996.
- [29] E. C. Skinner, A. S. Fairey, S. Groshen et al., "Randomized trial of studer pouch versus T-pouch orthotopic ileal neobladder in patients with bladder cancer," *The Journal of Urology*, vol. 194, no. 2, pp. 433–440, 2015.
- [30] A. Kristjansson, L. Wallin, and W. Mansson, "Renal function up to 16 years after conduit (refluxing or anti-reflux anastomosis) or continent urinary diversion. I. Glomerular filtration rate and patency of uretero-intestinal anastomosis," *British Journal of Urology*, vol. 76, no. 5, pp. 539–545, 1995.
- [31] W. S. Tan, A. Sridhar, M. Goldstraw et al., "Robot-assisted intracorporeal pyramid neobladder," *BJU International*, vol. 116, no. 5, pp. 771–779, 2015.
- [32] M. M. Desai, I. S. Gill, A. L. D. C. Abreu et al., "Robotic intracorporeal orthotopic neobladder during radical cystectomy in 132 patients," *The Journal of Urology*, vol. 192, no. 6, pp. 1734–1740, 2014.
- [33] R. E. Hautmann, B. G. Volkmer, M. C. Schumacher, J. E. Gschwend, and U. E. Studer, "Long-term results of standard procedures in urology: the ileal neobladder," *World Journal of Urology*, vol. 24, no. 3, pp. 305–314, 2006.
- [34] M. S. Eisenberg, R. H. Thompson, I. Frank et al., "Long-term renal function outcomes after radical cystectomy," *The Journal of Urology*, vol. 191, no. 3, pp. 619–625, 2014.
- [35] J. P. Stein, M. D. Dunn, M. L. Quek, G. Miranda, and D. G. Skinner, "The orthotopic T pouch ileal neobladder: experience with 209 patients," *Journal of Urology*, vol. 172, no. 2, pp. 584–587, 2004.
- [36] M. Ferriero, S. Guaglianone, R. Papalia, G. L. Muto, M. Gallucci, and G. Simone, "Risk assessment of stone formation in stapled orthotopic ileal neobladder," *Journal of Urology*, vol. 193, no. 3, pp. 891–896, 2015.
- [37] Z. Okhunov, B. Duty, A. D. Smith, and Z. Okeke, "Management of urolithiasis in patients after urinary diversions," *BJU International*, vol. 108, no. 3, pp. 330–336, 2011.
- [38] R. D. Mills and U. E. Studer, "Metabolic consequences of continent urinary diversion," *Journal of Urology*, vol. 161, no. 4, pp. 1057–1066, 1999.
- [39] F. Van der Aa, S. Joniau, M. Van Den Branden, and H. Van Poppel, "Metabolic changes after urinary diversion," *Advances in Urology*, vol. 2011, Article ID 764325, 5 pages, 2011.
- [40] L. E. Matarese, S. J. O'Keefe, H. M. Kandil, G. Bond, G. Costa, and K. Abu-Elmagd, "Short bowel syndrome: clinical guidelines for nutrition management," *Nutrition in Clinical Practice*, vol. 20, no. 5, pp. 493–502, 2005.
- [41] M. Fujisawa, I. Nakamura, N. Yamanaka et al., "Changes in calcium metabolism and bone demineralization after orthotopic intestinal neobladder creation," *Journal of Urology*, vol. 163, no. 4, pp. 1108–1111, 2000.
- [42] R. E. Hautmann, H. Abol-Enein, K. Hafez et al., "Urinary diversion," *Urology*, vol. 69, no. 1, supplement, pp. 17–49, 2007.
- [43] T. M. Kessler, F. C. Burkhard, P. Perimenis et al., "Attempted nerve sparing surgery and age have a significant effect on urinary continence and erectile function after radical cystoprostatectomy and ileal orthotopic bladder substitution," *Journal of Urology*, vol. 172, no. 4, pp. 1323–1327, 2004.
- [44] M. S. El Bahnasawy, Y. Osman, M. A. Gomha, A. A. Shaaban, A. Ashamallah, and M. A. Ghoneim, "Nocturnal enuresis in men with an orthotopic ileal reservoir: urodynamic evaluation," *Journal of Urology*, vol. 164, no. 1, pp. 10–13, 2000.
- [45] M. S. El-Bahnasawy, H. Shaaban, M. A. Gomha, and A. Nabeeh, "Clinical and urodynamic efficacy of oxybutynin and verapamil in the treatment of nocturnal enuresis after formation of orthotopic ileal neobladders. A prospective, randomized, crossover study," *Scandinavian Journal of Urology and Nephrology*, vol. 42, no. 4, pp. 344–351, 2008.
- [46] B. Ali-El-Dein, M. Gomha, and M. A. Ghoneim, "Critical evaluation of the problem of chronic urinary retention after orthotopic bladder substitution in women," *Journal of Urology*, vol. 168, no. 2, pp. 587–592, 2002.
- [47] J. P. Stein, D. A. Ginsberg, and D. G. Skinner, "Indications and technique of the orthotopic neobladder in women," *Urologic Clinics of North America*, vol. 29, no. 3, pp. 725–734, 2002.
- [48] G. Gakis, J. Efstathiou, S. P. Lerner et al., "ICUD-EAU international consultation on bladder cancer 2012: radical cystectomy and bladder preservation for muscle-invasive urothelial carcinoma of the bladder," *European Urology*, vol. 63, no. 1, pp. 45–57, 2013.
- [49] B. G. Volkmer, R. Kuefer, G. C. Bartsch Jr., K. Gust, and R. E. Hautmann, "Oncological follow up after radical cystectomy for bladder cancer-is there any benefit?" *Journal of Urology*, vol. 181, no. 4, pp. 1587–1593, 2009.
- [50] S. A. Boorjian, S. P. Kim, C. J. Weight, J. C. Cheville, P. Thapa, and I. Frank, "Risk factors and outcomes of urethral recurrence following radical cystectomy," *European Urology*, vol. 60, no. 6, pp. 1266–1272, 2011.

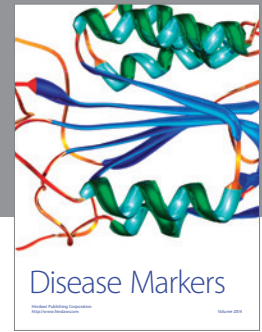

**Hindawi**  
Submit your manuscripts at  
<http://www.hindawi.com>

