

Research Article

A Theoretical Model of Listeriosis Driven by Cross Contamination of Ready-to-Eat Food Products

C. W. Chukwu  and F. Nyabadza

Department of Mathematics and Applied Mathematics, University of Johannesburg, Auckland Park 2006, South Africa

Correspondence should be addressed to C. W. Chukwu; wiliam.chukwu@gmail.com

Received 16 September 2019; Revised 15 January 2020; Accepted 23 January 2020; Published 9 March 2020

Academic Editor: Marianna A. Shubov

Copyright © 2020 C. W. Chukwu and F. Nyabadza. This is an open access article distributed under the Creative Commons Attribution License, which permits unrestricted use, distribution, and reproduction in any medium, provided the original work is properly cited.

Cross contamination that results in food-borne disease outbreaks remains a major problem in processed foods globally. In this paper, a mathematical model that takes into consideration cross contamination of *Listeria monocytogenes* from a food processing plant environment is formulated using a system of ordinary differential equations. The model has three equilibria: the disease-free equilibrium, Listeria-free equilibrium, and endemic equilibrium points. A contamination threshold (\mathcal{R}_{wf}) is determined. Analysis of the model shows that the disease-free equilibrium point is locally stable for $\mathcal{R}_{wf} < 1$ while the Listeria-free and endemic equilibria are locally stable for $\mathcal{R}_{wf} > 1$. The time-dependent sensitivity analysis is performed using Latin hypercube sampling to determine model input parameters that significantly affect the severity of the listeriosis. Numerical simulations are carried out, and the results are discussed. The results show that a reduction in the number of contaminated workers and removal of contaminated food products are essential in eliminating the disease in the human population and vice versa. The results have significant public health implications in the management and containment of any listeriosis disease outbreak.

1. Introduction

Listeria is a Gram-positive facultatively anaerobic bacillus (bacteria) which was discovered by E.G.D. Murray in 1924, and in 1926, it was finally classified as *Listeria monocytogenes* (*L. monocytogenes*) [1]. Among all the strains of Listeria, *Listeria innocua*, *Listeria seeligeri*, *Listeria welshimeri*, and *Listeria ivanovii*, only *Listeria monocytogenes* is pathogenic to both humans and animals [2]. It has an optimum growth temperature ranging between 30°C and 37°C and also at a refrigeration temperature of 4°C [3]. The main primary sources of *L. monocytogenes* are soil and water. It is then transmitted to animals, plant materials, and then to the food chain [2]. Listeria is one of the most common food-borne pathogens amongst others such as *Salmonella*, *Escherichia coli*, Norovirus, and *Campylobacter jejuni* which pose a great threat to the world population, thereby causing high fatality rates but with a low incidence rate [4]. The bacteria exist naturally in the environment and can be transmitted to food chain either through animals or into the production company by the

workers. Transmission of listeriosis is mainly due to food consumption by humans rather than the interaction of the humans and the environment [2]. Epidemiologically, after humans come in contact with Listeria, the causative agent of listeriosis remains in the gastrointestinal tract and survives and develops different strategies to counteract changes in acidity, osmolarity, oxygen tension, or the challenging effects of antimicrobial peptides and bile [5]. In the infected human, *L. monocytogenes* crosses the epithelium barrier through the transcytosis and invades the mesenteric lymph nodes and then into the blood [6]. Most of the bacteria are then trapped in the liver cells and become part of the circulatory system. Since *L. monocytogenes* survives and grows even in low temperatures, the survived bacteria replicates in the hepatocytes, thereby recruiting polymorphonuclear cells which lead to hepatocytes lysis. Finally, the bacteria are released, and they circulate in the blood of the host [4]. Furthermore, in the case of pregnant women, the bacteria are transmitted to the unborn foetus either during delivery or through the placenta.

The first case of the listeriosis outbreak was diagnosed in South Africa in the Western Cape province in 1977, with an average of 60–80 confirmed cases of the infected humans [7]. Recently, the outbreak occurred again in South Africa between January 2017 and June 2018 as a result of consumption of contaminated food products by consumers [8]. The source of this outbreak was traced to a food production company (majorly the meat processing facilities) that manufactures ready-to-eat (RTE) foods [8]. These are foods that are intended by the producers for direct human consumption without the need for cooking [9]. There were 1049 laboratory confirmed cases across the eight provinces, with Gauteng province having the highest number of infected individuals (58.2%, 611/1049), followed by Western Cape (12.6%, 132/1049) and KwaZulu-Natal (7.6%, 80/1049) provinces [3]. A total of 209 (26.9%) deaths were recorded as a result of the listeriosis disease outbreak [8, 10]. The most affected were neonates (babies less than 28 days old), followed by adults aged 15 to 49 years of age. Listeriosis has also been linked to be the cause of premature labour, death of new born babies, serious illness, meningitis, miscarriages, and stillbirth [3].

In recent years, several mathematical models [11–14], predictive microbiology models [15, 16], empirical models [15], and statistical models [17] have been used to model the growth, survival, and death rates of *Listeria*. None of these models consider the aspect of cross contamination, which is essential in the dynamics of listeriosis in humans. Cross contamination remains a common route for the spread of listeriosis. Cross contamination of *L. monocytogenes* in fish production plants was considered in [12], cross contamination of *L. monocytogenes* in pork bowl slicing was considered in [16], surface cross contamination of ready-to-eat meat via slicing operation was considered in [18], and modelling listeriosis disease dynamics in human and vector population was considered in [13]. Membré et al. [15] proposed an empirical model in a single step to describe the growth, survival, and death of *L. monocytogenes* as a function of temperature, sodium chloride (NaCl), and phenol compounds. The authors in [12] used a differential equation model which was based on the Reed–Frost model to describe transmission of contamination during cross contamination in production plant. The objective of this study is to present a more explicit mathematical model for cross contamination of *Listeria* occurring in a production plant such as slicing and packaging in the preparation of RTE foods and its impact on humans through consumption of RTE foods.

This paper is arranged as follows. Section 1 introduces the research paper followed by model formulation in Section

2. Basic properties of the model are presented in Section 3. Model analysis is done in Section 4, and numerical simulations presented in Section 5. The paper is concluded in Section 6.

2. Model Formulation

We develop a mathematical model for listeriosis disease in which the human population is divided into three classes, namely, susceptibles $S_h(t)$, infected $I_h(t)$, and recovered $R_h(t)$. We consider a constant human population over the modelling time. Individuals are recruited into the susceptible class at a rate $\mu_h N$ and upon infection move into the class I_h at a rate $\lambda_h(t)$. After treatment, infected individuals recover at a rate γ with no immunity. Those that recover lose immunity at a rate δ_h and become susceptible again once if they ingest contaminated RTE food [19]. Furthermore, the bacteria can grow or die in its hosts, soil, water, and environment. We denote the growth and death rates of *Listeria*, $L(t)$, by r_l and d , respectively. We assume a logistic growth for *Listeria* with a carrying capacity K_L . Uncontaminated workers $W_n(t)$ can be infected by *Listeria* from their working environment and through contaminated food at a rate $\lambda_w(t)$, defined later after the model equations. Infected workers $W_c(t)$ are assumed to contaminate uncontaminated food $F_n(t)$ at a rate $\lambda_f(t)$. The contaminated food $F_c(t)$ is then responsible for the transmission of *Listeria* to the human population. We assume that human population $N(t)$ comprises of those individuals that do not work in the factories, while $W(t)$ is the population of workers. The population of factory workers is assumed to be constant over the model time. The total amount of food products $F(t)$ that are manufactured is assumed to be constant over the modelling time. We therefore assume a natural mortality rate μ_h for all human classes and a removal rate of workers μ_w . Contaminated workers can be decontaminated at a rate δ_w , through hygiene and disinfectants. We also assume that θ_f is the rate of addition of noncontaminated food (rate of food processing) while μ_f is the rate of removal of food products. Assuming that we have a constant human population, the total population $N(t)$, the total number of workers $W(t)$, and the total amount of food products produced $F(t)$ at any time t are, respectively, given by

$$\begin{aligned} N(t) &= S_h(t) + I_h(t) + R_h(t), \\ W(t) &= W_n(t) + W_c(t), \\ F(t) &= F_n(t) + F_c(t). \end{aligned} \tag{1}$$

We assume that the population of workers is constant over the modelling time and contamination of food is only possible through the workers, i.e., no food is manufactured in a contaminated state.

Figure 1 and the assumptions stated in the model formulations give rise to a nonlinear system of differential equations describing the transmission of listeriosis from RTE food products to the human population given by

$$\begin{aligned} \frac{dS_h}{dt} &= \mu_h N + \delta_h R_h - (\mu_h + \lambda_h) S_h, \\ \frac{dI_h}{dt} &= \lambda_h S_h - (\mu_h + \gamma) I_h, \\ \frac{dR_h}{dt} &= \gamma I_h - (\mu_h + \delta_h) R_h, \\ \frac{dL}{dt} &= r_l L \left(1 - \frac{L}{K_L} \right) - dL, \\ \frac{dW_n}{dt} &= \delta_w W_c - (\lambda_w + \mu_w) W_n, \\ \frac{dW_c}{dt} &= \lambda_w W_n - (\mu_w + \delta_w) W_c, \\ \frac{dF_n}{dt} &= \theta_f - (\lambda_f + \mu_f) F_n, \\ \frac{dF_c}{dt} &= \lambda_f F_n - \mu_f F_c, \end{aligned} \tag{2}$$

where

$$\begin{aligned} \lambda_h &= \beta_{f_1} F_c, \\ \lambda_w &= \beta_L L + \beta_{f_2} F_c, \\ \lambda_f &= \beta_{w_1} W_c. \end{aligned} \tag{3}$$

All parameters for the model system (2) are assumed to be nonnegative for all time $t > 0$. From (1), we have $R_h(t) = N(t) - S_h(t) - I_h(t)$ and $W_n(t) = W(t) - W_c(t)$. Therefore, the system of equation (2) reduces to

$$\begin{aligned} \frac{dS_h}{dt} &= \mu_h N + \delta_h (N - S_h - I_h) - (\mu_h + \lambda_h) S_h, \\ \frac{dI_h}{dt} &= \lambda_h S_h - (\mu_h + \gamma) I_h, \\ \frac{dL}{dt} &= r_l L \left(1 - \frac{L}{K_L} \right) - dL, \\ \frac{dW_c}{dt} &= \lambda_w (W - W_c) - (\mu_w + \delta_w) W_c, \\ \frac{dF_n}{dt} &= \theta_f - (\lambda_f + \mu_f) F_n, \\ \frac{dF_c}{dt} &= \lambda_f F_n - \mu_f F_c, \end{aligned} \tag{4}$$

with the initial conditions given by

$$\begin{aligned} S_h(0) &= S_{h0} > 0, \\ I_h(0) &= I_{h0} \geq 0, \\ L(0) &= L_0 \geq 0, \\ W_c(0) &= W_{c0} \geq 0, \\ F_n(0) &= F_{n0} \geq 0, \\ F_c(0) &= F_{c0} \geq 0. \end{aligned} \tag{5}$$

Set

$$\begin{aligned} s_h &= \frac{S_h}{N}, \\ i_h &= \frac{I_h}{N}, \\ l &= \frac{L}{K_L}, \\ w_c &= \frac{W_c}{W}, \\ f_n &= \frac{F_n}{F}, \\ f_c &= \frac{F_c}{F}. \end{aligned} \tag{6}$$

We nondimensionalise (3) and obtain the following:

$$\begin{aligned} \frac{ds_h}{dt} &= \mu_h + \delta_h (1 - s_h - i_h) - (\mu_h + \tilde{\lambda}_h) s_h, \\ \frac{di_h}{dt} &= \tilde{\lambda}_h s_h - (\mu_h + \gamma) i_h, \\ \frac{dl}{dt} &= r_l l (1 - l) - dl, \\ \frac{dw_c}{dt} &= \tilde{\lambda}_w (1 - w_c) - (\mu_w + \delta_w) w_c, \\ \frac{df_n}{dt} &= \tilde{\theta}_f - (\tilde{\lambda}_f + \mu_f) f_n, \\ \frac{df_c}{dt} &= \tilde{\lambda}_f f_n - \mu_f f_c, \end{aligned} \tag{7}$$

where the nondimensionalised contamination rates are

$$\begin{aligned} \tilde{\lambda}_h &= \beta_{f_1} F f_c, \\ \tilde{\lambda}_w &= \beta_L l K_L + \beta_{f_2} F f_c, \\ \tilde{\lambda}_f &= \beta_{w_1} W w_c, \end{aligned} \tag{8}$$

and $\tilde{\theta}_f = (\theta_f/F)$, with initial conditions

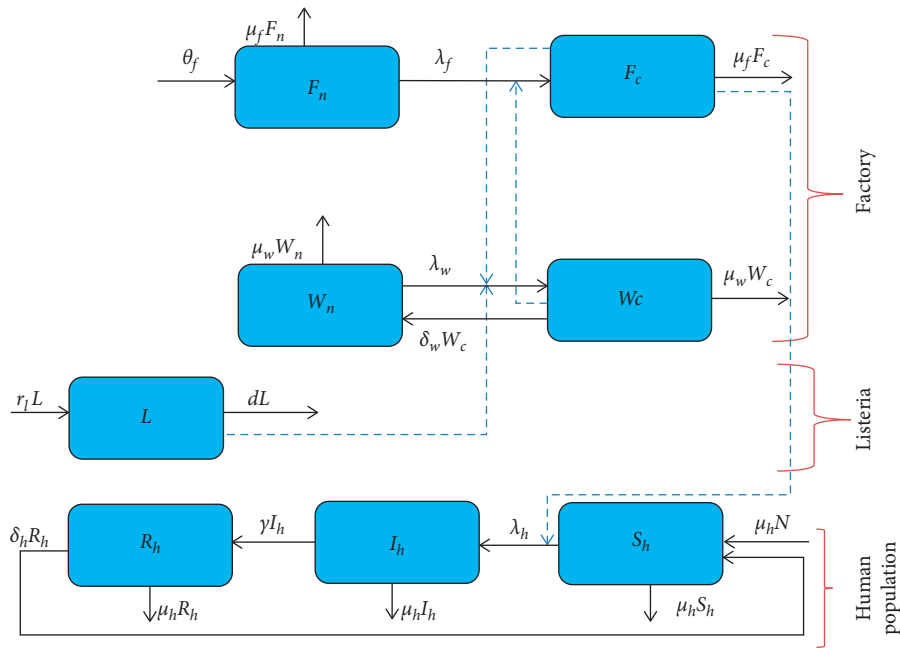

FIGURE 1: Compartmental model diagram for transmission of Listeria from factory (production plant) to human population. The bold arrows are transition arrows, while the dotted lines depict the effects of the corresponding compartments on the transitions.

$$\begin{aligned}
 s_h(0) &= s_{h0} > 0, \\
 i_h(0) &= i_{h0} \geq 0, \\
 l(0) &= l_0 \geq 0, \\
 w_c(0) &= w_{c0} \geq 0, \\
 f_n(0) &= f_{n0} \geq 0, \\
 f_c(0) &= f_{c0} \geq 0.
 \end{aligned}
 \tag{9}$$

$$s_h(t) \geq s_h(0)e^{-\left(\delta_h + \mu_h + \int \tilde{\lambda}_h(\tau) d\tau\right)} > 0, \tag{11}$$

where $s_h(0)$ is the given initial condition. From (11), we see that

$$\liminf_{t \rightarrow \infty} (s_h(t)) \geq 0. \tag{12}$$

Thus, the solution $s_h(t)$ will always be positive for all $t \geq 0$. Similarly, from the second equation of model system (7),

$$\frac{di_h}{dt} \geq -(\mu_h + \gamma)i_h, \tag{13}$$

which yields

$$i_h(t) \geq i_h(0)e^{-(\mu_h + \gamma)t} > 0, \tag{14}$$

where $i_h(0)$ is the initial condition. Similarly, solving the remaining equations of system (7) and taking limits as t approaches infinity, it can be shown that $l(t) > 0$, $w_c(t) > 0$, $f_n(t) > 0$, and $f_c(t) > 0$ for all time $t > 0$. This completes the proof. \square

3. Basic Properties

3.1. Positivity and Boundedness of Solutions. The aim here is to obtain nonnegative solutions, since the necessary conditions under which a differential equation is nonnegative are important in analysing real life problems from which the differential equations are derived. The listeriosis model will be epidemiologically and biologically meaningful if we can establish that all the solutions with nonnegative initial data remain nonnegative at all times, i.e., $t > 0$ and well posed. We apply Theorem 1 to ascertain our view.

Theorem 1. For nonnegative initial conditions (9), the solutions $(s_h(t), i_h(t), l(t), w_c(t), f_n(t), f_c(t))$ of the system (7) are all nonnegative for all $t \geq 0$.

Proof. From the first equation of the system (7), we have that

$$\frac{ds_h}{dt} \geq -(\delta_h + \mu_h + \tilde{\lambda}_h)s_h. \tag{10}$$

Solving the first-order differential equation (10) gives

3.2. Invariant Region. The biological feasible region (Γ) for the system (7) is in \mathbb{R}_+^6 . We show that it is dissipative, that is, all the feasible solutions are uniformly bounded. We thus have the following result.

Theorem 2. The solutions of model system (7) are contained in the region $\Gamma \in \mathbb{R}_+^6$, which is given by $\Gamma = \{(s_h, i_h, l, w_c, f_n, f_c) \in \mathbb{R}_+^6 : 0 \leq s_h + i_h \leq 1, 0 \leq l \leq 1, 0 \leq w_c \leq 1, 0 \leq f_n + f_c \leq (\theta_f / \mu_f)\}$, for the initial conditions (9) in Γ .

Proof. The total change in human population from the system of equation (7) is given by

$$\frac{dn}{dt} = \mu_h(1 - s_h - i_h) + \delta_h(1 - s_h - i_h) - \gamma i_h, \quad (15)$$

for $n = s_h + i_h \leq 1$. Let $\phi = (s_h + i_h)$ so that

$$\frac{d\phi}{dt} = \mu_h(1 - \phi) + \delta_h(1 - \phi) - \gamma i_h \leq (\mu_h + \delta_h)(1 - \phi). \quad (16)$$

The solution of (16) is

$$\phi(t) = 1 - \phi(0)e^{-(\mu_h + \delta_h)t}, \quad (17)$$

where $\phi(0) = s_h(0) + i_h(0)$ is the initial condition. Applying Birkhoff and Rota's [20] theorem on differential inequality and the condition, we have that $0 \leq n \leq 1 - \phi(0)e^{-(\mu_h + \delta_h)t}$ so that 1 is the upper bound of n provided that $\phi(0) \geq 1$. Thus, every solution to system (16) with initial conditions in Γ remains in Γ for all $t > 0$. Next, we consider the equation of the system (7) describing the transmission of the pathogen (Listeria) from the environment to the factory. We have that

$$\frac{dl}{dt} - (r_l - d)l = -r_l l^2, \quad (18)$$

and its differential inequality is

$$\frac{dl}{dt} = (r_l - d)l - r_l l^2 \leq (r_l - d). \quad (19)$$

Let $m = (r_l - d) > 0$. Equation (19) is a Bernoulli's equation, whose solution is obtained by setting $l = y^{-1}$. Solving the left hand side of (19), we obtain $l(t) \leq (m/(r_l + A_1 e^{-mt}))$. As $t \rightarrow \infty$, $l(t) \rightarrow (m/r_l)$. The Listeria grows asymptotically and is able to infect the host by causing cross contamination of RTE food in the factory. In a similar approach, we found the solutions for $f_n(t)$ and $w_c(t)$ to be

$$f_n(t) = \frac{\tilde{\theta}_f}{\mu_f} - A_2 e^{-\mu_f t}, \quad (20)$$

$$w_c(t) = 1 - A_3 e^{-\tilde{\lambda}_w t},$$

respectively. We note that $f_n(t) \rightarrow (\tilde{\theta}_f/\mu_f)$ and $w_c(t) \rightarrow 1$ asymptotically as $t \rightarrow \infty$. From the last equation of the system (7),

$$\frac{df_c}{dt} = \tilde{\lambda}_f f_n - \mu_f f_c. \quad (21)$$

Substituting $\tilde{\lambda}_f = \beta_{w_1} W w_c$ and $f_n = (\tilde{\theta}_f/\mu_f)$ which is the boundedness for the noncontaminated food, equation (21) becomes

$$\frac{df_c}{dt} = (\beta_{w_1} W w_c) \frac{\tilde{\theta}_f}{\mu_f} - \mu_f f_c \leq (\beta_{w_1} w_c) \frac{\tilde{\theta}_f}{\mu_f} - \mu_f f_c. \quad (22)$$

Let $\omega = (\beta_{w_1} w_c)(\tilde{\theta}_f/\mu_f)$; hence, (22) becomes

$$\frac{df_c}{dt} \leq \omega - \mu_f f_c. \quad (23)$$

The solution of (23) by the integration factor method is

$$f_c(t) = \frac{\omega}{\mu_f} - A_1 e^{-\mu_f t}. \quad (24)$$

Thus, $\limsup_{t \rightarrow \infty} (f_c(t)) \leq (\omega/\mu_f)$. Hence, considering the human population, Listeria, contaminated workers, noncontaminated food products, and contaminated food products, the regions in Γ are invariant and biologically meaningful. \square

4. Model Analysis

4.1. Listeriosis Model Equilibria. We solve for the equilibrium points for the system (7), by setting the right side of system (7) to zero, so that

$$\begin{aligned} \mu_h + \delta_h(1 - s_h^* - i_h^*) - (\mu_h + \tilde{\lambda}_h) s_h^* &= 0, \\ \tilde{\lambda}_h s_h^* - (\mu_h + \gamma) i_h^* &= 0, \\ r_l l^* (1 - l^*) - d l^* &= 0, \\ \tilde{\lambda}_w (1 - w_c^*) - (\mu_w + \delta_w) w_c^* &= 0, \\ \tilde{\theta}_f - (\tilde{\lambda}_f + \mu_f) f_n^* &= 0, \\ \tilde{\lambda}_f f_n^* - \mu_f f_c^* &= 0, \end{aligned} \quad (25)$$

with $\beta_1 = \beta_{f_1} F, \beta_2 = \beta_L K_L, \beta_3 = \beta_{f_2} F, \beta_4 = \beta_{w_1} W$, and $m = (r_l - d)$. Solving system (25) for the equilibrium points, from the third equation of system (25), we have

$$l^* (m - r_l l^*) = 0. \quad (26)$$

So $l^* = 0$ or $l^* = (m/r_l)$. Note that, for Listeria to exist, then $r_l > d$. Let $\tilde{\beta}_1 = \beta_1 f_c^*$; hence, the first and second equations of system (25) become

$$\begin{aligned} (\mu_h + \tilde{\beta}_1) s_h^* - \delta_h(1 - s_h^* - i_h^*) - \mu_h &= 0, \\ \tilde{\beta}_1 s_h^* - (\mu_h + \gamma) i_h^* &= 0. \end{aligned} \quad (27)$$

Solving (27) for s_h^* and i_h^* simultaneously, we have

$$\begin{aligned} s_h^* &= \frac{(\mu_h + \gamma)(\mu_h + \delta_h)}{(\mu_h + \delta_h)(\mu_h + \gamma) + \tilde{\beta}_1(\gamma + \delta_h + 1)}, \\ i_h^* &= \frac{\tilde{\beta}_1(\mu_h + \delta_h)}{(\mu_h + \delta_h)(\mu_h + \gamma) + \tilde{\beta}_1(\gamma + \delta_h + 1)}. \end{aligned} \quad (28)$$

Using the fourth equation, we obtain

$$\begin{aligned} (\beta_2 l^* + \beta_3 f_c^*)(1 - w_c^*) - (\mu_w + \delta_w) w_c^* &= 0, \\ \implies w_c^* &= \frac{\beta_2 l^* + \beta_3 f_c^*}{\beta_2 l^* + \beta_3 f_c^* + \mu_w + \delta_w}. \end{aligned} \quad (29)$$

On the other hand, from the last equation of (25) we have that

$$f_n^* = \frac{\mu_f f_c^*}{\tilde{\lambda}_f} \quad (30)$$

Substituting (30) into the second last equation of (25) and after some algebraic manipulations, we obtain the following quadratic expression:

$$\nu_2 f_c^{*2} + \nu_1 f_c^* + \nu_0 = 0, \quad (31)$$

where

$$\begin{aligned} \nu_0 &= -\beta_2 \beta_4 \tilde{\theta}_f l^* < 0, \\ \nu_1 &= -\beta_3 \beta_4 \tilde{\theta}_f + \beta_2 \beta_4 \mu_f l^* + \beta_2 \mu_f^2 l^* + \mu_w \mu_f^2 + \delta_w \mu_f^2, \\ \nu_2 &= \beta_3 \beta_4 \mu_f + \beta_3 \mu_f^2 > 0. \end{aligned} \quad (32)$$

Note that $\nu_1 < 0$ or $\nu_1 > 0$.

When $l^* = 0$,

$$\nu_2 (f_c^*)^2 + \nu_1 f_c^* = 0. \quad (33)$$

Now, solving for f_c^* , we obtain

$$\begin{aligned} f_{c_1}^* &= 0 \\ \text{or } f_{c_2}^* &= \frac{-\nu_1}{\nu_2}. \end{aligned} \quad (34)$$

Considering the case $f_{c_2}^* = (-\nu_1/\nu_2)$, we have

$$\begin{aligned} f_{c_2}^* &= \frac{\beta_3 \beta_4 \tilde{\theta}_f - \mu_f^2 \mu_w - \mu_f^2 \delta_w}{\beta_3 \beta_4 \mu_f + \beta_3 \mu_f^2} \\ &= \frac{\mu_f (\mu_w + \delta_w)}{\beta_3 (\beta_4 + \mu_f)} \left(\frac{\beta_3 \beta_4 \tilde{\theta}_f}{\mu_f^2 (\mu_w + \delta_w)} - 1 \right) \\ &= \Phi_1 (\mathcal{R}_{wf} - 1), \end{aligned} \quad (35)$$

where

$$\begin{aligned} \Phi_1 &= \frac{\mu_f (\mu_w + \delta_w)}{\beta_3 (\beta_4 + \mu_f)}, \\ \mathcal{R}_{wf} &= \frac{\beta_3 \beta_4 \tilde{\theta}_f}{\mu_f^2 (\mu_w + \delta_w)}. \end{aligned} \quad (36)$$

We thus call \mathcal{R}_{wf} the contamination threshold. We thus have the following result on the existence of $f_{c_2}^*$.

Lemma 1. *The steady-state $f_{c_2}^*$ exists if and only if $\mathcal{R}_{wf} > 1$.*

It is important to note that \mathcal{R}_{wf} denotes the measure of contamination caused by workers and food products. This is equivalent to the reproduction number (\mathcal{R}_0) in disease modelling [21], where \mathcal{R}_0 determines whether a disease is established or eradicated. In this case, \mathcal{R}_{wf} determines whether listeriosis is established or eradicated, i.e., no contamination of food products.

If $f_{c_1}^* = 0$, then $w_c^* = 0$ and $\tilde{\lambda}_h = 0$ which gives $i_h^* = 0$ and

$$s_h^* = \frac{(\mu_h + \delta_h - \delta_h i_h^*)}{(\delta_h + \mu_h + \tilde{\lambda}_h)} = 1, \quad (37)$$

and $f_{n_1}^* = (\tilde{\theta}_f/\mu_f)$. This results in the disease-free equilibrium (DFE) point E_0^* given by

$$E_0^* = (s_h^*, i_h^*, l_0^*, f_{n_1}^*, w_{c_1}^*, f_{c_1}^*) = \left(1, 0, 0, 0, \frac{\tilde{\theta}_f}{\mu_f}, 0 \right). \quad (38)$$

At DFE, there are no Listeria, contaminated workers, food, and infected and recovered humans. Given that

$$w_c^* = \frac{\beta_3 f_c^*}{\beta_3 f_c^* + \mu_w + \delta_w}, \quad (39)$$

when $l^* = 0$, we have

$$w_{c_2}^* = \frac{\beta_3 (\beta_3 \beta_4 \tilde{\theta}_f - \mu_f^2 (\mu_w + \delta_w))}{\beta_3 (\beta_3 \beta_4 \tilde{\theta}_f - \mu_f^2 (\mu_w + \delta_w)) + \beta_3 \mu_f (\mu_w + \delta_w) (\beta_4 + \mu_f)}. \quad (40)$$

Some algebraic manipulations give

$$w_{c_2}^* = \Phi_2 (\mathcal{R}_{wf} - 1), \quad (41)$$

where $\Phi_2 = ((\mu_f^2 (\mu_w + \delta_w)) / (\beta_4 (\beta_3 \tilde{\theta}_f + \mu_f (\mu_w + \delta_w))))$. Solving for $f_{n_2}^*$ by substituting (35) and (41) into (30), we obtain

$$\begin{aligned} f_{n_2}^* &= \frac{\beta_3 \tilde{\theta}_f + \mu_f (\mu_w + \delta_w)}{\beta_3 (\beta_4 + \mu_f)}, \\ &= \Phi_3 \left(\frac{\mu_f}{\beta_4} \mathcal{R}_{wf} + 1 \right), \end{aligned} \quad (42)$$

where $\Phi_3 = (\mu_f (\mu_w + \delta_w) / \beta_3 (\beta_4 + \mu_f))$. We thus have the Listeria-free equilibrium point:

$$E_1^* = (s_h^*, i_h^*, l_1^*, f_{n_2}^*, w_{c_2}^*, f_{c_2}^*), \quad (43)$$

where

$$s_h^* = \frac{(\mu_h + \gamma) (\mu_h + \delta_h)}{(\mu_h + \delta_h) (\mu_h + \gamma) + \beta_1 \Phi_1 (\mathcal{R}_{wf} - 1) (\gamma + \delta_h + 1)},$$

$$i_h^* = \frac{\tilde{\beta}_1 (\mu_h + \delta_h)}{(\mu_h + \delta_h) (\mu_h + \gamma) + \beta_1 \Phi_1 (\mathcal{R}_{wf} - 1) (\gamma + \delta_h + 1)},$$

$$l_1^* = 0,$$

$$w_{c_2}^* = \Phi_2 (\mathcal{R}_{wf} - 1),$$

$$f_{n_2}^* = \Phi_3 \left(\frac{\mu_f}{\beta_4} \mathcal{R}_{wf} + 1 \right),$$

$$f_{c_2}^* = \Phi_1 (\mathcal{R}_{wf} - 1). \quad (44)$$

This implies that as long as we have contaminated workers or food, we will still have the disease in the human population. Thus, removal of contaminated food is essential for disease control. When $l^* \neq 0$, then

$$\begin{aligned} \nu_0 &= -\beta_2\beta_4\tilde{\theta}_f l^* < 0, \\ \nu_1 &= \beta_2\mu_f l^* (\beta_4 + \mu_f) + \mu_f^2 (\mu_w + \delta_w)(1 - \mathcal{R}_{wf}), \\ \nu_2 &= \beta_3\beta_4\mu_f + \beta_3\mu_f^2 > 0. \end{aligned} \tag{45}$$

Solving (31) for f_c^* , we obtain

$$f_c^* = \frac{-\nu_1 \pm \sqrt{\nu_1^2 - 4\nu_2\nu_0}}{2\nu_2} \tag{46}$$

If $\nu_1 > 0$ and $\nu_1 < 0$, we have one positive solution. Thus, irrespective of the sign of ν_1 , we have one positive root for f_c^* , say f_c^{**} . From (25), we now have

$$\begin{aligned} \tilde{\lambda}_h &= \beta_1 f_c^{**}, \\ \tilde{\lambda}_w &= \beta_2 l^* + \beta_3 f_c^{**}, \\ \tilde{\lambda}_f &= \beta_4 w_c^*, \\ \tilde{\theta}_f &= \frac{\theta_f}{F}, \end{aligned} \tag{47}$$

with $l^* = (m/r_1)$. Let $\tilde{\beta}_1^+ = \beta_1 f_c^{**}$, and similarly solving for s_h^{**} and i_h^{**} simultaneously, we obtain

$$\begin{aligned} s_h^{**} &= \frac{(\mu_h + \gamma)(\mu_h + \delta_h)}{(\mu_h + \delta_h)(\mu_h + \gamma) + \tilde{\beta}_1^+(\gamma + \delta_h + 1)}, \\ i_h^{**} &= \frac{\tilde{\beta}_1^+(\mu_h + \delta_h)}{(\mu_h + \delta_h)(\mu_h + \gamma) + \tilde{\beta}_1^+(\gamma + \delta_h + 1)}. \end{aligned} \tag{48}$$

If $\tilde{\lambda}_w = \beta_2 l^* + \beta_3 f_c^{**}$, then from the fourth equation of (25), we obtain

$$w_c^{**} = \frac{\beta_2 l^* + \beta_3 f_c^{**}}{\beta_2 l^* + \beta_3 f_c^{**} + \mu_w + \delta_w} \tag{49}$$

Now, setting $\tilde{\lambda}_f = \beta_4 w_c^{**}$ from second last equation of (25), we have

$$\eta_2 (f_c^{**})^2 + \eta_1 f_c^{**} + \eta_0 = 0, \tag{50}$$

where

$$\begin{aligned} \eta_2 &= \beta_3(\beta_4 + \mu_f^2) > 0, \\ \eta_1 &= -\beta_3\beta_4\tilde{\theta}_f + \beta_2\mu_f \frac{m}{r_1} (\beta_4 + \mu_f) + \mu_f^2 (\mu_w + \delta_w), \\ \eta_0 &= -\beta_2\beta_4\tilde{\theta}_f \frac{m}{r_1} < 0. \end{aligned} \tag{51}$$

Further simplification of η_1 gives the following expression:

$$\eta_1 = \beta_2\mu_f \frac{m}{r_1} (\beta_4 + \mu_f) + \mu_f^2 (\mu_w + \delta_w)(1 - \mathcal{R}_{wf}). \tag{52}$$

However, we note that if $\mathcal{R}_{wf} > 1$, then $\eta_1 < 0$, and if $\mathcal{R}_{wf} < 1$, then $\eta_1 > 0$. Hence, solving (50) for f_c^{**} , we obtain

$$f_c^{**} = \frac{-\eta_1 \pm \sqrt{\eta_1^2 - 4\eta_2\eta_0}}{2\eta_2} \tag{53}$$

If $\eta_1 > 0$ or $\eta_1 < 0$, (53) we will always have one positive root. Therefore, irrespective of the sign of η_1 , we will always have one positive root. We thus have the following result.

Theorem 3. Model system (7) has a unique endemic equilibrium as long as $m > 0$, i.e., $r_1 > d$.

Remark 1. As long as the growth rate of Listeria is greater than the death rate, we will always have listeriosis.

Also, note that f_c^{**} is the positive root of (50). We cannot explicitly write the expression of the roots for f_c^{**} due to the intractability of expression (50). Thus, the endemic equilibrium,

$$E_2^* = (s_h^{**}, i_h^{**}, l_2^*, w_c^{**}, f_n^{**}), \tag{54}$$

is given by

$$\begin{aligned} s_h^{**} &= \frac{(\mu_h + \gamma)(\mu_h + \delta_h)}{(\mu_h + \delta_h)(\mu_h + \gamma) + \tilde{\beta}_1^+(\gamma + \delta_h + 1)}, \\ i_h^{**} &= \frac{\tilde{\beta}_1^+(\mu_h + \delta_h)}{(\mu_h + \delta_h)(\mu_h + \gamma) + \tilde{\beta}_1^+(\gamma + \delta_h + 1)}, \\ l_2^* &= \frac{m}{r_1}, \\ w_c^{**} &= \frac{\beta_2 l^* + \beta_3 f_c^{**}}{\beta_2 l^* + \beta_3 f_c^{**} + \mu_w + \delta_w}, \\ f_{n_2}^{**} &= \frac{\beta_3 \tilde{\theta}_f + \mu_f (\mu_w + \delta_w)}{\beta_3 (\beta_4 + \mu_f)}. \end{aligned} \tag{55}$$

We note that at endemic equilibrium, there is infection in the human population as a result of ingestion of contaminated RTE foods. Also, the workers and the food are contaminated.

4.2. Stability of Equilibria Points

4.2.1. Local Stability of the Disease-Free Equilibrium. We now state the following theorem for the local stability of disease-free equilibrium.

Theorem 4. The equilibrium point E_0^* is locally asymptotically stable if and only if $r_1 < d$ and $\mathcal{R}_{wf} < 1$; otherwise, it is unstable.

Proof. The Jacobian of system (7) is given by the block matrix:

$$J = \begin{pmatrix} A & B \\ C & D \end{pmatrix}, \tag{56}$$

where

$$\begin{aligned}
 A &= \begin{pmatrix} -(\delta_h + \mu_h + \beta_1 f_c^*) & -\delta_h & 0 \\ \beta_1 f_c^* & -(\mu_h + \gamma) & 0 \\ 0 & 0 & (r_l - 2r_l l^* - d) \end{pmatrix}, \\
 B &= \begin{pmatrix} 0 & 0 & -\beta_1 s_h^* \\ 0 & 0 & \beta_1 s_h^* \\ 0 & 0 & 0 \end{pmatrix}, \\
 C &= \begin{pmatrix} 0 & 0 & \beta_2(1 - w_c^*) \\ 0 & 0 & 0 \\ 0 & 0 & 0 \end{pmatrix}, \\
 D &= \begin{pmatrix} -(\beta_2 l^* + \beta_3 f_c^* + \mu_w + \delta_w) & 0 & \beta_3(1 - w_c^*) \\ -\beta_4 f_n^* & -(\beta_4 w_c^* + \mu_f) & 0 \\ \beta_4 f_n^* & \beta_4 w_c^* & -\mu_f \end{pmatrix}.
 \end{aligned} \tag{57}$$

Evaluating at DFE (E_0^*) , we have that

$$J(E_0^*) = \left(\begin{array}{c|c} J_1(E_0^*) & J_2(E_0^*) \\ \hline J_3(E_0^*) & J_4(E_0^*) \end{array} \right), \tag{58}$$

where

$$\begin{aligned}
 J_1(E_0^*) &= \begin{pmatrix} -(\delta_h + \mu_h) & -\delta_h & 0 \\ 0 & -(\mu_h + \gamma) & 0 \\ 0 & 0 & (r_l - d) \end{pmatrix}, \\
 J_2(E_0^*) &= \begin{pmatrix} 0 & 0 & -\beta_1 \\ 0 & 0 & \beta_1 \\ 0 & 0 & 0 \end{pmatrix}, \\
 J_3(E_0^*) &= \begin{pmatrix} 0 & 0 & \beta_2 \\ 0 & 0 & 0 \\ 0 & 0 & 0 \end{pmatrix}, \\
 J_4(E_0^*) &= \begin{pmatrix} -(\mu_w + \delta_w) & 0 & \beta_3 \\ -\beta_4 \frac{\tilde{\theta}_f}{\mu_f} & -\mu_f & 0 \\ \beta_4 \frac{\tilde{\theta}_f}{\mu_f} & 0 & -\mu_f \end{pmatrix}.
 \end{aligned} \tag{59}$$

The eigenvalues from $J_1(E_0^*)$ are $\lambda_1 = (r_l - d) < 0$ provided that $r_l < d$, $\lambda_2 = -(\mu_w + \delta_w)$, and $\lambda_3 = -(\mu_h + \gamma)$. The

rest of the eigenvalues are determined from $J_4(E_0^*)$, which is the solution of the cubic equation:

$$\lambda^3 + \xi_2 \lambda^2 + \xi_1 \lambda + \xi_0 = 0, \tag{60}$$

given that

$$\begin{aligned}
 \xi_0 &= -\beta_3 \beta_4 \theta_f \mu_f + \mu_f^3 (\delta_w + \mu_w), \\
 \xi_1 &= -\beta_3 \beta_4 \theta_f + \mu_f^2 (2\delta_w + \mu_f + 2\mu_w), \\
 \xi_2 &= \mu_f (2\mu_f + \mu_w + \delta_w) > 0.
 \end{aligned} \tag{61}$$

Further simplification of ξ_1 and ξ_0 gives

$$\begin{aligned}
 \xi_1 &= \mu_f^3 + 2\mu_f^2 (\mu_w + \delta_w) \left(1 - \frac{\beta_3 \beta_4 \theta_f}{2\mu_f^2 (\mu_w + \delta_w)} \right), \\
 &= \mu_f^3 + 2\mu_f^2 (\mu_w + \delta_w) \left(1 - \frac{1}{2} \mathcal{R}_{wf} \right), \\
 \xi_0 &= \mu_f^2 (\mu_w + \delta_w) \left(1 - \frac{\beta_3 \beta_4 \theta_f}{\mu_f^2 (\mu_w + \delta_w)} \right) \mu_f, \\
 &= \mu_f^3 (\mu_w + \delta_w) (1 - \mathcal{R}_{wf}),
 \end{aligned} \tag{62}$$

respectively. We note that if $\mathcal{R}_{wf} < 1$, then $\xi_1 > 0$ and $\xi_0 > 0$. Next, we show that $\xi_2 \xi_1 > \xi_0$ as follows:

$$\begin{aligned}
 &\mu_f (2\mu_f + \mu_w + \delta_w) \left[\mu_f^3 + 2\mu_f^2 (\mu_w + \delta_w) \left(1 - \frac{1}{2} \mathcal{R}_{wf} \right) \right] \\
 &= (2\mu_f + \mu_w + \delta_w) \left[\mu_f^4 + 2\mu_f^3 (\mu_w + \delta_w) \left(1 - \frac{1}{2} \mathcal{R}_{wf} \right) \right] \\
 &> \mu_f^3 (\mu_w + \delta_w) (2 - \mathcal{R}_{wf}) > \mu_f^3 (\mu_w + \delta_w) (1 - \mathcal{R}_{wf}).
 \end{aligned} \tag{63}$$

Note that $2 - \mathcal{R}_{wf} > 1 - \mathcal{R}_{wf}$ if $\mathcal{R}_{wf} < 1$. Thus, according to Routh–Hurwitz criteria, all the roots of (60) have negative real parts. \square

4.2.2. *Local Stability of the Listeria-Free Equilibrium.* We state the following theorem for the local stability of Listeria-free equilibrium.

Theorem 5. *The equilibrium E_1^* is locally asymptotically stable if and only if $r_1 < d$ and $\mathcal{R}_{wf} \geq 1$; otherwise, it is unstable.*

Proof. Evaluating the Jacobian of system (7) at E_1^* gives

$$J(E_1^*) = \begin{pmatrix} J_1(E_1^*) & | & J_2(E_1^*) \\ \hline J_3(E_1^*) & | & J_4(E_1^*) \end{pmatrix}, \tag{64}$$

where

$$\begin{aligned} J_1(E_1^*) &= \begin{pmatrix} -(\delta_h + \mu_h + \beta_1 f_{c_2}^*) & -\delta_h & 0 \\ \beta_1 f_{c_2}^* & -(\mu_h + \gamma) & 0 \\ 0 & 0 & (r_1 - d) \end{pmatrix}, \\ J_2(E_1^*) &= \begin{pmatrix} 0 & 0 & -\beta_1 s_h^* \\ 0 & 0 & \beta_1 s_h^* \\ 0 & 0 & 0 \end{pmatrix}, \\ J_3(E_1^*) &= \begin{pmatrix} 0 & 0 & \beta_2(1 - w_{c_2}^*) \\ 0 & 0 & 0 \\ 0 & 0 & 0 \end{pmatrix}, \\ J_4(E_1^*) &= \begin{pmatrix} -(\beta_3 f_{c_2}^* + \mu_w + \delta_w) & 0 & \beta_3(1 - w_{c_2}^*) \\ -\beta_4 f_{n_2}^* & -(\beta_4 w_{c_2}^* + \mu_f) & 0 \\ \beta_4 f_{n_2}^* & \beta_4 w_{c_2}^* & -\mu_f \end{pmatrix}. \end{aligned} \tag{65}$$

The eigenvalues from $J_1(E_1^*)$ are $\lambda_1 = (r_1 - d) < 0$ provided that $r_1 < d$, which is the case given by Listeria-free equilibrium and the solutions of the quadratic equation:

$$\lambda^2 + \zeta_1 \lambda + \zeta_0 = 0, \tag{66}$$

where

$$\begin{aligned} \zeta_0 &= (\gamma \beta_1 f_{c_2}^* + \gamma \delta_h + \beta_1 \delta_h f_{c_2}^* + \gamma \mu_h + \beta_1 \mu_h f_{c_2}^* + \delta_h \mu_h + \mu_h^2) > 0, \\ \zeta_1 &= (\gamma + \beta_1 f_{c_2}^* + \delta_h + 2\mu_h) > 0. \end{aligned} \tag{67}$$

The eigenvalues of (66) have negative real parts since $\zeta_0 > 0$ and $\zeta_1 > 0$ using Routh–Hurwitz criterion. The rest of the eigenvalues are obtained from $J_4(E_1^*)$, which are the solutions to the cubic equation:

$$\lambda^3 + \zeta_4 \lambda^2 + \zeta_3 \lambda + \zeta_2 = 0, \tag{68}$$

where

$$\begin{aligned} \zeta_2 &= (\mu_f + \beta_4 w_{c_2}^*)(\mu_f \delta_w + \mu_f \mu_w + \mu_f \beta_3 f_{c_2}^*) \\ &\quad + (w_{c_2}^* - 1)\beta_3 \beta_4 f_{n_2}^*, \\ \zeta_3 &= \mu_f(2\delta_w + \mu_f + 2\mu_w + \beta_4 w_{c_2}^* + 2\beta_3 f_{c_2}^*) \\ &\quad + \beta_4 w_{c_2}^*(\delta_w + \mu_w + \beta_3 f_{c_2}^*) - \beta_3 \beta_4 f_{n_2}^*(1 - w_{c_2}^*), \\ \zeta_4 &= (\delta_w + 2\mu_f + \mu_w + \beta_4 w_{c_2}^* + \beta_3 f_{c_2}^*) > 0. \end{aligned} \tag{69}$$

We note that if $w_{c_2}^* > 1$, then $\zeta_2 > 0$ and $\zeta_3 > 0$. Next, we show that $\zeta_4 \zeta_3 > \zeta_2$ as follows:

$$\begin{aligned} \zeta_4 \zeta_3 &= (\delta_w + 2\mu_f + \mu_w + \beta_4 w_{c_2}^* + \beta_3 f_{c_2}^*)(2\mu_f \delta_w + \mu_f^2 + 2\mu_f \mu_w \\ &\quad + \beta_4 w_{c_2}^* \mu_f + 2\beta_3 f_{c_2}^* \mu_f) + \beta_3 \beta_4 f_{n_2}^*(w_{c_2}^* - 1) > \zeta_2. \end{aligned} \tag{70}$$

Thus, by the Routh–Hurwitz criterion, the eigenvalues of (68) have negative real parts. Thus, E_1^* is locally asymptotically stable. \square

4.2.3. *Local Stability of the Endemic Equilibrium.* We state the following theorem for the local stability of endemic equilibrium.

Theorem 6. *The equilibrium point E_2^* is locally asymptotically stable if $\mathcal{R}_{wf} \geq 1$ and unstable otherwise.*

Proof. Evaluating the Jacobian of system (7) at E_2^* gives

$$J(E_2^*) = \begin{pmatrix} J_1(E_2^*) & | & J_2(E_2^*) \\ \hline J_3(E_2^*) & | & J_4(E_2^*) \end{pmatrix}, \tag{71}$$

where

$$\begin{aligned} J_1(E_2^*) &= \begin{pmatrix} -(\delta_h + \mu_h + \beta_1 f_{c_2}^{*+}) & -\delta_h & 0 \\ \beta_1 f_{c_2}^{*+} & -(\mu_h + \gamma) & 0 \\ 0 & 0 & (r_1 - 2r_1 \frac{m}{r_1} - d) \end{pmatrix}, \\ J_2(E_2^*) &= \begin{pmatrix} 0 & 0 & -\beta_1 s_h^{*+} \\ 0 & 0 & \beta_1 s_h^{*+} \\ 0 & 0 & 0 \end{pmatrix}, \\ J_3(E_2^*) &= \begin{pmatrix} 0 & 0 & \beta_2(1 - w_{c_2}^{*+}) \\ 0 & 0 & 0 \\ 0 & 0 & 0 \end{pmatrix}, \\ J_4(E_2^*) &= \begin{pmatrix} -\tau & 0 & \beta_3(1 - \varphi) \\ -\beta_4 \delta & -(\beta_4 \varphi + \mu_f) & 0 \\ \beta_4 \delta & \beta_4 \varphi & -\mu_f \end{pmatrix}, \end{aligned} \tag{72}$$

given that $\tau = (\beta_2(m/r_1) + \beta_3 f_{c_2}^{*+} + \mu_w + \delta_w) > 0$, $\varphi = w_{c_2}^{*+} = (\beta_2(m/r_1) + \beta_3 f_{c_2}^{*+} / \beta_2(m/r_1) + \beta_3 f_{c_2}^{*+} + \mu_w + \delta_w) > 0$, and

TABLE 1: Parameter values used for simulations.

Parameter	Symbol	Point value (day ⁻¹)
Mortality of humans	μ_h	0.02/365
Removal rate of workers	μ_w	0.00274
Removal rate of food products	μ_f	0.0099
Recovery rate of humans	γ	0.034
Recovery rate of workers	δ_w	0.0008
Rate of lost of immunity by humans	δ_h	0.2
Growth rate of listeriosis	r_l	0.32
Death rate of listeriosis	d	0.25
Listeria carrying capacity	K_L	0.008
Food contamination rate by contaminated workers	β_{w_1}	0.0048
Contact rate of listeriosis by humans	β_{f_1}	0.008
Workers contamination rate by contaminated food	β_{f_2}	0.00056
Contact rate of contaminated workers by Listeria	β_L	0.7
Food products	F	10
Workers	W	5
Rate of food processing	θ_f	0.055

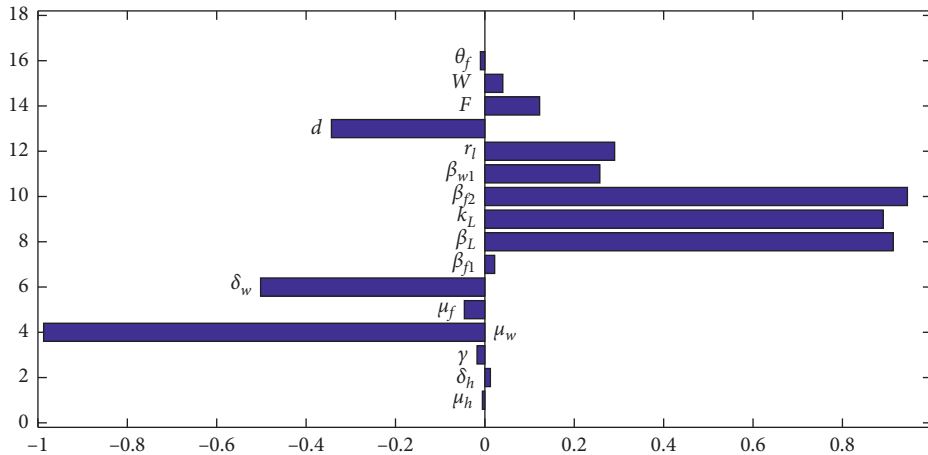

FIGURE 2: Tornado plots showing PRCCs of different parameter values driving the listeriosis disease.

$\delta = f_n^{*+} > 0$. The eigenvalues of $J_1(E_2^*)$ are $\lambda_3 = -(r_l - d)$, and the solutions of the quadratic equation are

$$\lambda^2 + b_1\lambda + b_0 = 0, \tag{73}$$

where

$$\begin{aligned} b_0 &= (\beta_1 f_c^{*+} (\gamma + \delta_h + \mu_h) + \gamma(\delta_h + \mu_h) + \mu_h(\delta_h + \mu_h)) > 0, \\ b_1 &= (\beta_1 f_c^{*+} + \gamma + \delta_h + 2\mu_h) > 0. \end{aligned} \tag{74}$$

The eigenvalues of (73) have negative real parts since from Routh–Hurwitz criterion $b_0 > 0$ and $b_1 > 0$. The rest of the eigenvalues are obtained from $J_4(E_1^*)$, which are the solutions to the cubic equation:

$$\lambda^3 + b_4\lambda^2 + b_3\lambda + b_2 = 0, \tag{75}$$

where

$$\begin{aligned} b_2 &= \mu_f(\tau\varphi\beta_4 + \tau\mu_f + \beta_3\beta_4\delta(\varphi - 1)), \\ b_3 &= \tau\varphi\beta_4 + \mu_f(2\tau + \varphi\beta_4 + \mu_f) + \beta_3\beta_4\delta(\varphi - 1), \\ b_4 &= (\tau + \varphi\beta_4 + 2\mu_f) > 0. \end{aligned} \tag{76}$$

We note that if $\varphi > 1$, then $b_2 > 0$ and $b_3 > 0$. Also, it is clear that $b_4 b_3 > b_2$. Therefore, their eigenvalues have negative real parts using the principles of Routh–Hurwitz criterion. Hence, E_2^* is locally stable. \square

5. Numerical Simulations

5.1. *Parameter Estimation.* In this section, we present numerical simulations of the model system (7) which was done using the sets of parameters values given in Table 1. There are very few mathematical models done on *L. monocytogenes*; hence, parameter values cannot be easily found from the literature. We thus estimate the parameter values. We have

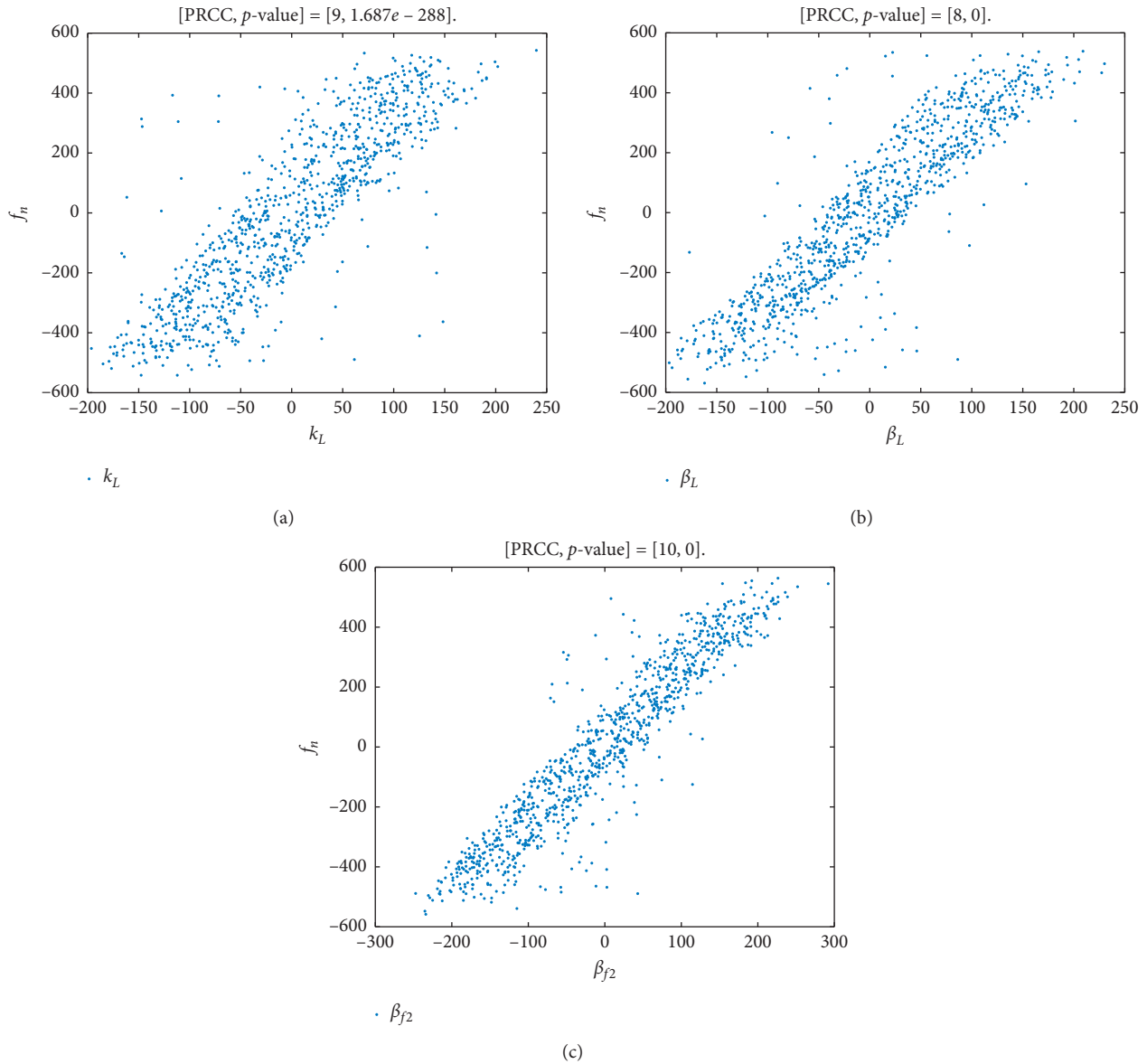

FIGURE 3: (a) Scatter plot of parameter carrying capacity of Listeria (k_L) with positive PRCC. (b) Scatter plot of parameter contact rate of Listeria by workers (β_L) with positive PRCC. (c) Scatter plot of parameter worker contamination rate from contaminated food products (β_{f_2}) with positive PRCC.

used fourth-order Runge–Kutta numerical scheme in Matlab with a unit time step 1 to carry out the simulations with the initial values: $s_h(0) = 0.6$, $i_h(0) = 0.2$, $l(0) = 0.2$, $w_c(0) = 0.3$, $f_n = 0.8$, and $f_c = 0.2$. The initial conditions are hypothetically chosen and are for illustrative purposes only and are not meant to represent any real scenario. This is useful for confirming some of the analytical results in this paper.

5.2. Sensitivity Analysis. In this section, we used the sensitivity analysis method known as the Latin hypercube sampling [22], which is an uncertainty analysis method to determine which parameters of the model are responsible for generating variability in the value of the model output. This method calculates the partial rank correlation coefficients

(PRCCs) given an input value to the model. We did our simulation using 1000 runs and all the parameters as an input. The parameters that are significant to our model are depicted in the tornado plot (Figure 2). The parameters k_L , β_L , and β_{f_2} were found to have PRCCs >0 while δ_w and μ_w have PRCCs <0 as shown in the scatter plots of Figures 3 and 4, respectively. This has also been shown in Figure 2. Thus, an increase in k_L , β_L , or β_{f_2} will increase the listeriosis disease epidemic and the decrease in δ_w or μ_w will decrease the disease variability.

5.3. Effects of Parameters β_{f_2} , μ_f , δ_w , and β_{w_1} on Contamination Threshold (\mathcal{R}_{wf}). In this section, we investigate the effect of varying parameters on \mathcal{R}_{wf} . Figure 5(a) shows that as the number of contamination rate of workers by the

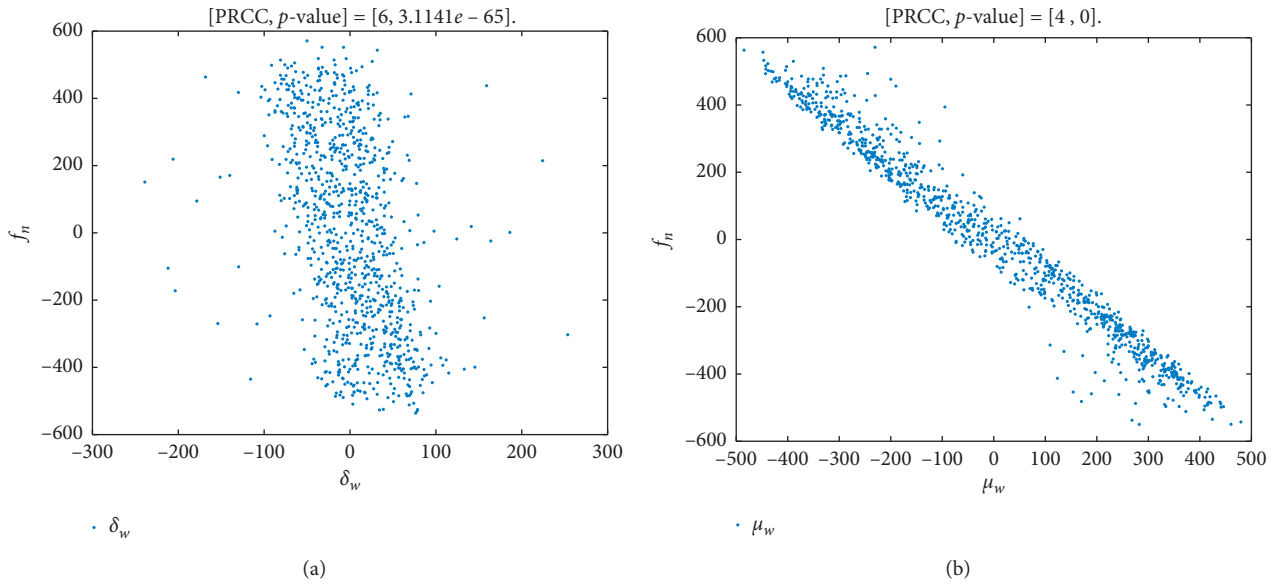

FIGURE 4: (a) Scatter plot of parameter removal rate of contaminated workers (δ_w) with negative PRCC. (b) Scatter plot of parameter removal rate of workers (μ_w) with negative PRCC.

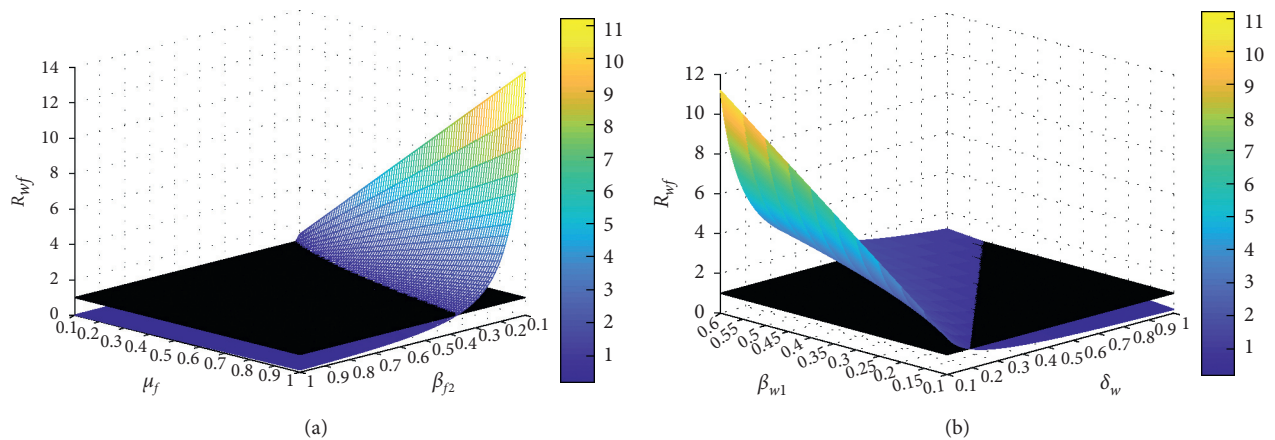

FIGURE 5: (a) 3D plot showing the effect of β_{f_2} and removal of food products (μ_f) on \mathcal{R}_{wf} . (b) 3D plot showing the effect of removal of workers (δ_w) and rate of contamination of food products by workers (β_{w_1}) on \mathcal{R}_{wf} .

contaminated food products increases, the number of \mathcal{R}_{wf} increases; this will result in invasion of the listeriosis disease epidemic. On the other hand, the increase in the removal of the food product (μ_f) decreases the values of the contamination threshold (\mathcal{R}_{wf}), which will cause the disease to be eradicated (see Figure 5(a)). Similarly, the increase in the removal of the number of contaminated workers (δ_w) decreases \mathcal{R}_{wf} , which means that the rate of progression of the contamination of food products by the workers in the factory decreases, and hence the epidemic is contained as depicted by Figure 5(b). Furthermore, increase in the rate of food contamination by the workers (β_{w_1}) increases the rate at which humans get infected with the disease due to high value of $\mathcal{R}_{wf} > 1$, as a result of more food products getting contaminated in the production plant.

5.4. Effects of Varying β_{f_2}, β_{w_1} , and δ_w on the Dynamics of Listeriosis. We did simulations with some of the model parameters to find out its effect on the listeriosis disease dynamics. We varied the rate of contamination workers by the food products (β_{f_2}) against the number of infected humans. It was found that the increase in the contamination rate of workers by contaminated food products results in the increase in the fraction of infected humans. Hence, the increase in β_{f_2} increases \mathcal{R}_{wf} as shown in Figure 6(a). Also, an increase in removal of the contaminated workers results in a decrease in the values of \mathcal{R}_{wf} , and hence less fraction of humans get infected, as depicted in Figure 6(c). Simulations also reveal that an increase in the rate of contamination of food by contaminated workers (β_{w_1}) increases \mathcal{R}_{wf} and the fractions of infected humans. Therefore, the disease can never be eradicated (see Figure 6(b)).

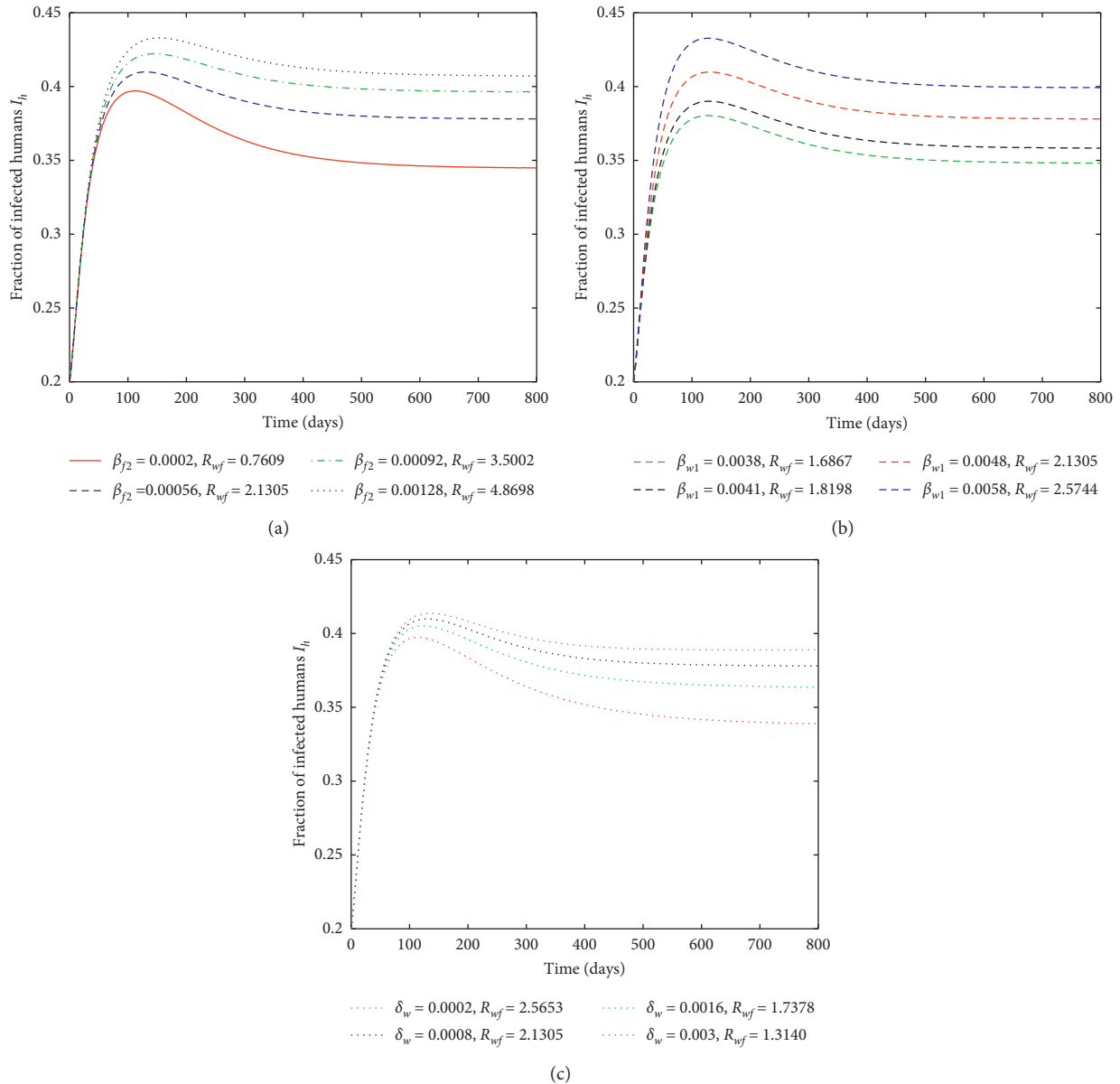

FIGURE 6: (a) Effects of contaminated Food (β_{f_2}) on the fractions of infected humans. (b) Effect rate of food contamination by contaminated workers (β_{w_1}) on the fractions of infected humans. (c) Effect of removal of contaminated workers (δ_w) on the fractions of infected humans.

6. Conclusion

This paper presents a mathematical model for cross contamination of the listeriosis disease, due to the consumption of ready-to-eat food products from production plant by humans. The analytical results of the model have shown that there exists a domain where the model is epidemiologically and mathematically well posed. The model contamination threshold (\mathcal{R}_{wf}) was determined during the process of solving for the equilibrium points. Three equilibria were found analytically, which are the disease-free (E_0^*), the Listeria-free (E_1^*), and the endemic (E_2^*) points. The analytical method has shown that the disease-free equilibrium is asymmetrically locally stable for $\mathcal{R}_{wf} < 1$ and asymptotically locally stable for $\mathcal{R}_{wf} > 1$

for both Listeria-free and endemic equilibrium points, respectively. The Jacobian matrix of system (7) was calculated, and the principle of Routh–Hurwitz criterion was used to deduce the local stability of the equilibria points in our analytical results. Sensitivity analysis shows that carrying capacity of Listeria (K_L), workers’ contamination rate by Listeria (β_L), workers’ contamination rate by contaminated food products (β_{f_2}), removal rate of contaminated workers (δ_w), and removal rate of workers (μ_w) are the most sensitive parameters of the model system (7), since they have high significant PRCC values. Further numerical simulations reveal that increase in the number of contaminated food products and the rate of contamination of food by contaminated workers increases the contamination of listeriosis by humans.

While the model presented in this paper presents some interesting aspects on cross contamination and *Listeria* infection dynamics, it has some aspects that require further examination and modelling. First, our population structure could have a nonsusceptible group of individuals who can be infected by listeriosis. However, in this work, we do not consider this particular group of individuals and this could be an interesting aspect to consider. Second, the model does not consider the fact that many people do not eat processed meats, and thus a fraction of the population should be considered as susceptible. Third, it is documented that the disease mainly affects the young, pregnant women, and the elderly. It will thus be prudent to consider an age structured model for such a disease. Fourth, different people, mount different levels of immune response to the disease and hence, an in-host model could be used to model how different people respond to the disease upon infection. Lastly, the model assumptions on the constant population of humans and workers could be relaxed to obtain a more accurate prediction of the model output with respect to the infection. Despite these weaknesses, the model still presents some interesting results on listeriosis dynamics and can easily be used to influence policy, especially if it is fitted to epidemiological data.

Data Availability

No data were used to support this study.

Conflicts of Interest

The authors declare that there are no conflicts of interest.

Acknowledgments

The authors would like to thank the Faculty of Science in the University of Johannesburg.

References

- [1] H. Hof, *History and Epidemiology of Listeriosis*, FEMS Immunology and Medical Microbiology, vol. 35, no. 3, Blackwell Publishing Ltd., Oxford, UK, 2003.
- [2] K. Linke, I. Rückerl, K. Brugger et al., "Reservoirs of *Listeria* species in three environmental ecosystems," *Applied and Environmental Microbiology*, vol. 80, no. 18, pp. 5583–5592, 2014.
- [3] NICD, National Institute of Communicable Disease, Listeriosis, "Clinical recommendations for diagnosis and treatment," 2019, <http://www.nicd.ac.za/listeriosis-clinical-recommendations-for-diagnosis-and-treatment/>.
- [4] V. Goulet, L. A. King, V. Vaillant, and H. de Valk, "What is the incubation period for listeriosis?" *BMC Infectious Diseases*, vol. 13, no. 1, p. 11, 2013.
- [5] M. Schuppler and M. J. Loessner, "The opportunistic pathogen *Listeria monocytogenes*: pathogenicity and interaction with the mucosal immune system," *International Journal of Inflammation*, vol. 2010, Article ID 704321, 12 pages, 2010.
- [6] G. Nikitas, C. Deschamps, O. Disson, T. Niaux, P. Cossart, and M. Lecuit, "Transcytosis of *Listeria monocytogenes* across the intestinal barrier upon specific targeting of goblet cell accessible E-cadherin," *The Journal of Experimental Medicine*, vol. 208, no. 11, pp. 2263–2277, 2011.
- [7] E. Tambo, C. S. Yah, and G. Madjou, "Deadly listeriosis outbreaks in South Africa and Australia: re-inforcing food safety surveillance and emergency response actions," *Journal of Advances Virology Research*, vol. 1, no. 1, p. 101, 2018.
- [8] NLIMIT, National Listeria Incident Management Team, "Listeriosis outbreak situation report," 2019, <http://www.health.gov.za/index.php/component/phocadownload/category/439>.
- [9] A. Ricci, A. Allende, D. Bolton, M. Chemaly et al., "Listeria monocytogenes contamination of ready-to-eat foods and the risk for human health in the EU," *EFSA Journal*, vol. 16, 2018.
- [10] WHO, *Listeriosis-South Africa*, WHO, Geneva, Switzerland, 2019, <https://www.who.int/csr/don/28-march-2018-listeriosis-south-africa/en>.
- [11] H. Khassehkhani and H. J. Eberl, "A computational study of amensalistic control of *Listeria monocytogenes* by *Lactococcus lactis* under nutrient rich conditions in a chemostat setting," *Journal of Foods*, vol. 5, no. 4, p. 61, 2016.
- [12] R. Ivanek, Y. T. Gröhn, M. Wiedmann, and M. T. Wells, "Mathematical model of *Listeria monocytogenes* cross-contamination in a fish processing plant," *Journal of Food Protection*, vol. 67, no. 12, pp. 2688–2697, 2004.
- [13] S. Osman, O. D. Makinde, and D. M. Theuri, "Stability analysis and modelling of listeriosis dynamics in human and animal populations," *Global Journal of Pure and Applied Mathematics*, vol. 14, no. 1, pp. 115–137, 2018.
- [14] O. Mejlholm and P. Dalgaard, "Modeling and predicting the growth boundary of *Listeria monocytogenes* in lightly preserved seafood," *Journal of Food Protection*, vol. 70, no. 1, pp. 70–84, 2007.
- [15] J. M. Membré, J. Thurette, and M. Catteau, "Modelling the growth, survival and death of *Listeria monocytogenes*," *Journal of Applied Microbiology*, vol. 82, no. 3, pp. 345–350, 1997.
- [16] R. Jiang, X. Wang, W. Wang et al., "Modelling the cross-contamination of *Listeria monocytogenes* in pork during bowl chopping," *International Journal of Food Science & Technology*, vol. 53, no. 3, pp. 837–846, 2018.
- [17] A. S. SantAna, B. D. G. M. Franco, and D. W. Schaffner, "Modeling the growth rate and lag time of different strains of *Salmonella enterica* and *Listeria monocytogenes* in ready-to-eat lettuce," *Food Microbiology*, vol. 30, no. 1, pp. 267–273, 2012.
- [18] S. Sheen and C.-A. Hwang, "Modeling the surface cross-contamination of *Salmonella* spp. on ready-to-eat meat via slicing operation," *Food and Nutrition Sciences*, vol. 2, no. 9, pp. 916–924, 2011.
- [19] B. Swaminathan and P. Gerner-Smidt, "The epidemiology of human listeriosis," *Microbes and Infection*, vol. 9, no. 10, pp. 1236–1243, 2007.
- [20] G. Birkhoff and G.-C. Rota, *Ordinary Differential Equations*, John Wiley and Sons, Inc., Vancouver, Canada, 3rd edition, 2002.
- [21] O. Diekmann, J. A. P. Heesterbeek, and J. A. J. Metz, "On the definition and the computation of the basic reproduction ratio R_0 in models for infectious diseases in heterogeneous populations," *Journal of Mathematical Biology*, vol. 28, no. 4, pp. 365–382, 2002.
- [22] M. D. McKay, R. J. Beckman, and W. J. Conover, "Comparison of three methods for selecting values of input variables in the analysis of output from a computer code," *Technometrics*, vol. 21, no. 2, pp. 239–245, 1979.